

N 1407



# Sailor

# Sailor

**INSTRUKTIONSBOG FOR  
SAILOR N1407**

**INSTRUCTION BOOK FOR  
SAILOR N1407**



**A/S S. P. RADIO · AALBORG · DENMARK**

## CONTENTS:

1. GENERAL DESCRIPTION
  - 1.1 TECHNICAL DATA
  - 1.2 PRINCIPLE OF OPERATION
2. SERVICE
  - 2.1 MAINTENANCE
  - 2.2 RECOMMENDED MEASUREMENT INSTRUMENTS
  - 2.3 PERFORMANCE CHECK
  - 2.4 SELF-MADE TEST LOAD
  - 2.5 NECESSARY ADJUSTMENTS AFTER REPAIR
  - 2.6 TROUBLE SHOOTING
  - 2.7 PIN CONFIGURATION
3. CIRCUIT DESCRIPTION AND DIAGRAMS WITH MEASUREMENTS
  - 3.1 INPUT FILTER (MODULE 400)
  - 3.2 POWER UNIT I
  - 3.3 POWER UNIT II
  - 3.4 BLOWER CONVERTER (MODULE 300)
4. COMPONENT LOCATIONS:
  - 4.1 CAPACITOR UNIT (MODULE 100)
  - 4.2 PUI AND PUII CONTROL UNIT (MODULE 200)
  - 4.3 BLOWER CONVERTER (MODULE 300)
  - 4.4 INPUT FILTER AND FUSES (MODULE 400)
  - 4.5 CHASSIS MOUNTING (MODULE 500)
  - 4.9 DISASSEMBLING FROM T1130
  - 4.10 MAIN DIAGRAM
- 5 PART LISTS

CONTENTS:

1. GENERAL DESCRIPTION
- 1.1 TECHNICAL DATA
- 1.2 PRINCIPLE OF OPERATION

## 1. GENERAL DESCRIPTION

SAILOR N1407 is a DC power supply intended to supply a SAILOR SSB short wave station from programme 1000/B, when the set has to be supplied from a 24V battery.

SAILOR N1407 is an integral part of the transmitter T1130 and all the controls of the power supply takes place via electrical wires.

SAILOR N1407 . The information to control N1407 comes from the short wave station and is established from the commands given to the set via the push buttons in the rack and from the mode selected on the exciter and receiver by the operator.

SAILOR N1407 with MAIN SWITCH in position RX-ONLY. Only the receiver is in operation and low power consumption is achieved.

SAILOR N1407 is provided with a thermostat which starts the fans for the power supply, if the temperature inside the power supply gets too high.

## 1.1. TECHNICAL DATA

The power supply N1407 delivers all necessary voltages to a SAILOR 1000/B SSB short wave set with an output power of 400 W PEP in the frequency range 1.6 - 27.5 MHz.

INPUT VOLTAGE:                   Nominal voltage 24 V  
                                  Extreme voltage 21.6 - 31.2 V

INPUT CURRENT:                   by 26.4V DC input  
                                  2-tone approx. 30A  
                                  A3J     approx. 17A  
                                  A3H     approx. 24A  
                                  R.O.    approx. 2.5A

OUTPUT VOLTAGES:                DC stabilized:  
                                  22V  $\pm 2\%$      $I_{max}$  3.2A  
                                  8V  $\pm 2\%$       $I_{max}$  2.0A  
                                  28V  $\pm 2\%$      $I_{max}$  3.4A  
                                  38V  $\pm 2\%$      $I_{max}$  14A  
                                  DC unstabilized:  
                                  -45V          $I_{max}$  0.15A  
                                  AC unstabilized:  
                                   $V_{blower} = V_{im} - 2xV_{sat}, I_{max}$  2A  
                                  frequency                       60 Hz

OPERATION TEMPERATURE RANGE: -15°C to +55°C

COOLING:                        As long as the power supply supplies a receiver and an unkeyed transmitter, the cooling takes place via convection only.

When the transmitter is keyed or the internal temperature of the power supply is above +55°C the blowers inside the T1130 unit are continuously running and cooling down the power supply and the transmitter. When the temperature falls below +45°C the blowers stop.

If temperature in transmitter is too high, the power supply is reduced from 38V to 30V. If temperature is further increasing, the Power Unit II is blocked and blowers start. When temperature is decreased blowers stop, and Power Unit II is unblocked again.

## 1.2. PRINCIPLE OF OPERATION

The power supply N1407 consists of three power supplies.

Power Unit I is a 400 Hz DC converter which delivers low power voltages for receiver, exciter and transmitter.

Power Unit II is also a 400 Hz push-pull converter which delivers high power to the transmitter.

The blower converter produces an AC voltage for the blowers.

PUI is working when the set is switched on.

PUII is only working when PUI is switched on and the transmitter is keyed.

N1407 is switched ON/OFF by the switches in H1235 rack system.

Maximum loads for the output voltages:

PUII	38V	:	$I_{Lmax} = 14A$	$R_L = 2.7 \text{ ohm}$	(600 W)
	28V	:	$I_{Lmax} = 3.4A$	$R_L = 8.2 \text{ ohm}$	(100 W)
	22V		$I_{Lmax} = 3.2A$	$R_L = 6.8 \text{ ohm}$	(75 W)
PUI	8V	:	$I_{Lmax} = 2.0A$	$R_L = 4.0 \text{ ohm}$	(20 W)
	-45V	:	$I_{Lmax} = 0.15A$	$R_L = 300 \text{ ohm}$	(10 W)

It is necessary to have all outputs loaded with their max. load, when the current limiters are adjusted.

To ensure proper regulation it is necessary that the power supply has a minimum load.

PUI: min. load for 22V output is approx. 22 ohm (no load at 8V and at -45V output)

PUII: min. load to 38V output is approx. 50 ohm (no load at 28V output)

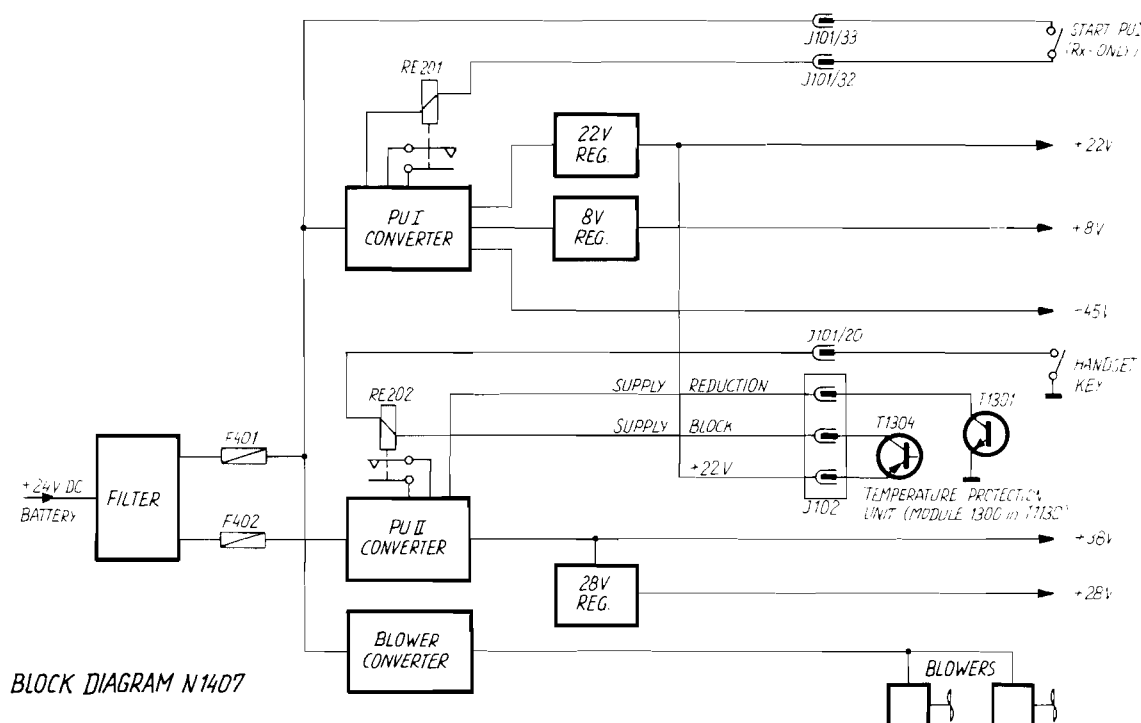

CONTENTS:

- 2. SERVICE
- 2.1 MAINTENANCE
- 2.2 RECOMMENDED MEASUREMENT INSTRUMENTS
- 2.3 PERFORMANCE CHECK
- 2.4 SELF-MADE TEST LOAD
- 2.5 NECESSARY ADJUSTMENTS AFTER REPAIR
- 2.6 TROUBLE SHOOTING
- 2.7 PIN CONFIGURATION

## 2. SERVICE

### 2.1. MAINTENANCE

When the SAILOR Short Wave Set type 1000/B has been correctly installed, the maintenance of the power supply can dependent on the environments and working hours be reduced to a performance check at the service workshop at intervals not exceeding 5 years.

A performance check list is enclosed in the PERFORMANCE CHECK section.

Also inspect cables and plugs for mechanical defects and corrosion.

Any repair of the set should be followed by a check described in the section NECESSARY ADJUSTMENTS AFTER REPAIR.

### 2.2. RECOMMENDED MEASUREMENT INSTRUMENTS

MULTIMETER ..... PHILIPS PM2505

OSCILLOSCOPE ..... PHILIPS PM3214

### 2.3. PERFORMANCE CHECK

1. N1407 is mounted in T1130 (1000/B rack).
2. Connect 24V DC to plug P103.
3. Push "RX-ONLY" (switches on PUI).
4. Check 22V output voltage. If necessary then adjust to 22.0V with R238.
5. Check 8V output voltage. If necessary then adjust to 8.0V with R241.
6. Check -45V output voltage to approx. -40V.
7. Push "ON" button and press key.
8. Check 28V and 38V output voltages. If necessary then adjust to 28V with R271 and to 38V with R259.
9. Current limiters cannot be adjusted.
10. While pressing the key or short-circuiting the thermal breaker TB501 check that both blowers are running.
11. When the blowers are running then check the blower converter. Measure with oscilloscope that the output frequency is 60 Hz (16.67 ms) and the pulse time is 7.5 ms.



2.4 SELF MADE TEST LOAD.

\* Switch is closed when adjusting the current limiter (R243 in N 1407)(R133 in 1409)

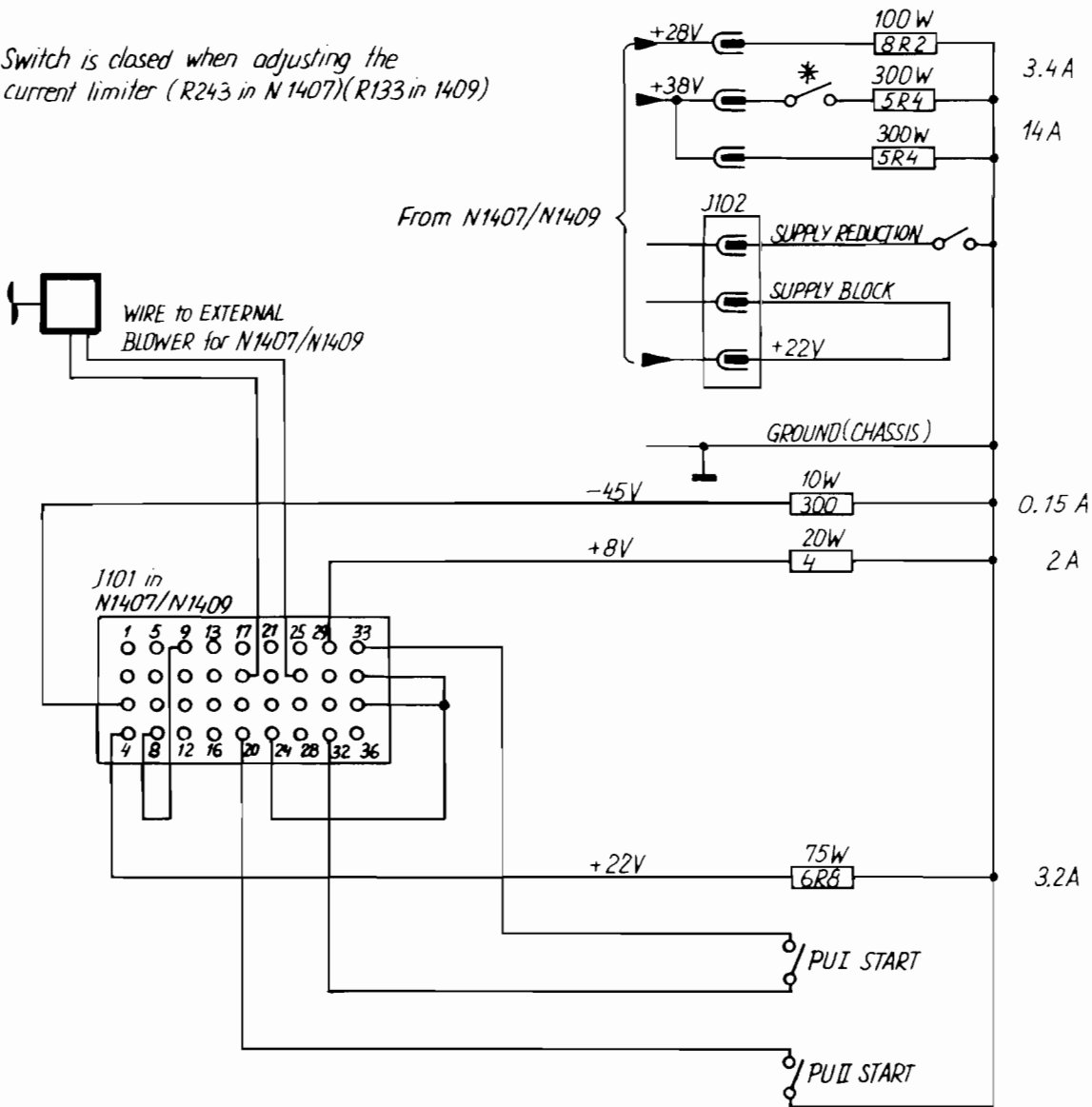

SELFMADE TEST LOAD FOR N1407/N1409

## 2.5. NECESSARY ADJUSTMENTS AFTER REPAIR

(using selfmade test load)

### POWER UNIT I

1. Connect selfmade test load to N1407 outputs.
2. Remove fuse F402.
3. Connect 24V DC to plug P103.
4. Switch on PUI.
5. Adjust 22V output with R238 to 22.0V.
6. Adjust 8V output with R241 to 8.0V.
7. Check -45V output (approx. -40V).
8. Switch off PUI.

### POWER UNIT II

When PUII is switched on, it is always necessary to cool the switch transistors T504 and T505 and the output rectifier D505. It is recommended to mount N1407 in a T1130 chassis with a blower to cool the power supply.

1. Remove the connection wire from the collectors of T504 and T505 to the transformer TR502.
2. Check the output voltage of PUI.
3. Connect scope ground to negative input voltage (negative pole of C503) and scope probe to the base of T504.
4. Replace F402.
5. Switch on PUI and PUII and check the base driver (see fig. on diagram).
6. Switch off PUI and PUII and connect scope probe to the base of T505.
7. Switch on PUI and PUII and check the base driver (see fig. on diagram).
8. Switch off PUI and PUII.
9. Connect the transformer TR502 to the collectors of T504 and T505.
10. Switch on PUI and PUII.
11. Turn R243 out of current limiting.  
Adjust 38V output with R259 to 38.0V.  
Adjust 28V output with R271 to 28.0V.  
Adjust current limiter with R243 so the 38V output is 35.5V with full load at 38V output and at 28V output.
12. Let the power supply work for about an hour and then check again the output voltages. Adjust if there has been some deviation.

## BLOWER CONVERTER

1. Switch on PUI and PUII. The blowers have to run.
2. Connect scope ground to the negative pole of the input voltage and scope probe to IC302 pin 1 (or pin 2). Adjust with R305 so that the frequency is 60 Hz (16.67 ms).
3. Connect scope probe to IC303 pin 3. Adjust with R311 so that the pulse time is 7.5 ms.

## 2.6. TROUBLE SHOOTING

### Failure in Power Unit I.

1. Bad connections in plug P103 or J101.
2. Fuse F401 is blown out.
  - a) The converter transistors T501 and T502 or the output stage in the blower converter are short-circuited.
3. PUI will not start up.
  - a) Check the relay RE201 and the voltage to it.
4. The converter starts up, but the output voltages are wrong.
  - a) Check the outputs severally.
  - b) Failure in the relays RE203, RE204 and RE205 or in the transistors T205 and T206.

### Failure in Power Unit II.

1. Relay RE202 is not activated when handset key is pressed.
  - a) PUI is out of function.
  - b) Handset key is out of function.
2. Supply is blocked.
  - a) Temperature protection unit in T1130 blocks the power supply because of overheating of the transistors in the power amplifier in T1130.  
Check also the blowers and air filter.
  - b) Bad connection of J102.
  - c) Over- and under voltage shut-down at IC201.
3. Supply starts up, but goes into "hiccup mode".
  - a) Wrong adjustment of current limiter R243.
  - b) Output voltage is short-circuited or overloaded.
  - c) Too low input voltage.

Failure in the Blower Converter.

1. Blowers will not stop.
  - a) Too high temperature in the power supply.
  - b) Too high temperature in the transmitter.
  - c) Bad connection in J102.
  - d) Thermal breaker is short-circuited.
  - e) Dirty air filter.
2. Blowers will not run.
  - a) On/off circuit consisting of OC301, T301 and T302 is out of function.
  - b) Wrong frequency of IC301.
  - c) Wrong pulse time of IC303.

# 3.8. PIN CONFIGURATION

FRONT VIEW

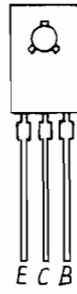

BD131  
BD138  
BD680  
BDX43  
BDX47

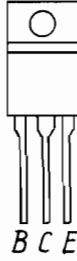

BD649  
BD650  
BD808  
BDX34B

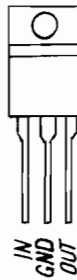

MC7824CT



LM317T

BOTTOM VIEW

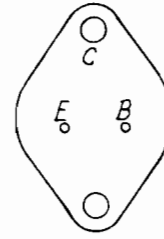

MJ802  
BUV19  
BUS12  
BUX98



BC338  
BC547  
BC548  
BC557  
BC558



BC639  
BC640



MPS-A06



MC78L08ACP

TOP VIEW

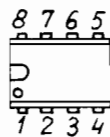

MC1455PI  
LM358N

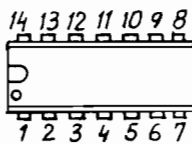

MC1723CP  
MC14013BCP

TOP VIEW

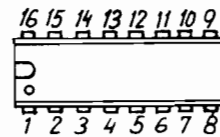

TDA1060A

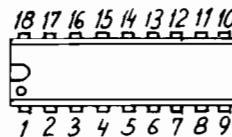

TDA4718A

N146

PIN CONFIGURATION cont.

MC1723

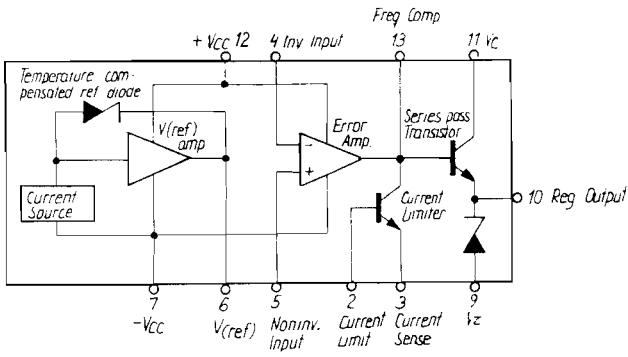

MC1455

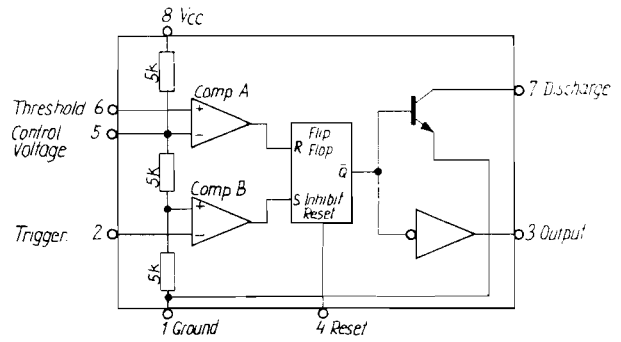

TDA 1060

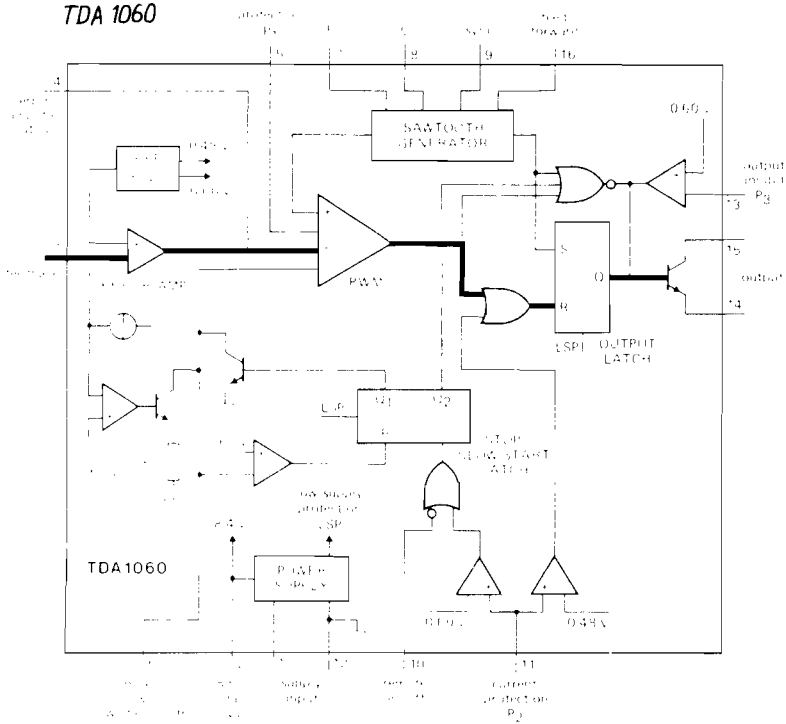

Block diagram of the TDA 1060

MC 14013 B

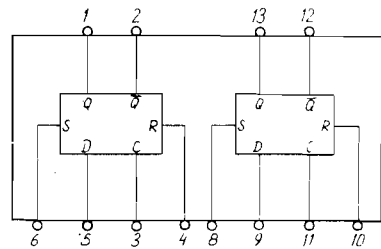

VDD = Pin 14  
VSS = Pin 7

TDA 4718

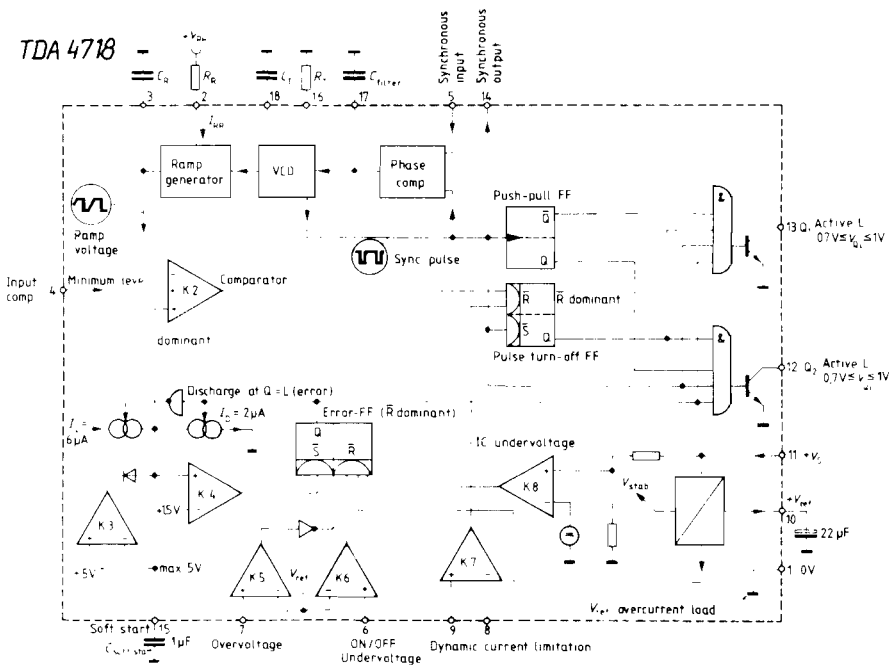

LM358

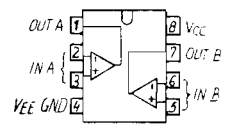

407 109

CONTENTS:

3. CIRCUIT DESCRIPTION AND DIAGRAMS WITH MEASUREMENTS
  - 3.1 INPUT FILTER (MODULE 400)
  - 3.2 POWER UNIT I
  - 3.3 POWER UNIT II
  - 3.4 BLOWER CONVERTER (MODULE 300)

### 3. CIRCUIT DESCRIPTIONS AND DIAGRAMS WITH MEASUREMENTS

#### 3.1. INPUT FILTER (MODULE 400)

The filter consists of capacitors and a filter choke L401 to suppress switch noise. It fulfils the CISPR noise regulation.

The fuse F401 protects Power Unit I and the blower converter. Fuse F402 protects Power Unit II. The diodes D401 and D402 protects against reverse polarity of the input voltage to P103.

#### 3.2. POWER UNIT I

In the rack system H1235 the terminals J101/32 and J101/33 are short circuited and relay RE201 is activated when starting up the PUI. The converter, consisting of TR201, TR501, T501 and T502, starts up and delivers voltage to the three secondary outputs.

-45V output is only rectified in D205 and is not regulated. The voltage is -34 to -54V depending of the input voltage. -45V to the receiver is switched on/off by the transistors T205 and T206. They are controlled by relay RE203 which also switches on/off the 22V and 8V to the receiver.

22V output is regulated after the switch mode principle by IC202 and is adjusted with R238. Transistor T203 turns on and the current flows through L501 and L502 to the load. The voltage increases at pin 4 and IC202 turns off T203. The current flows continuously in L501 and back through D210. The voltage decreases at pin 4 and IC202 turns on T203 again. The regulator is then self oscillating. R233 forms a current limiter.

8V output is a linear series regulator controlled by IC203. The output voltage is adjusted with R241. IC203 is supplied from 22V output which means that 8V is present only if 22V is present.

The relays RE204 and RE205 switch on the voltage to T1130 and to the exciter.

#### 3.3. POWER UNIT II

When the transmitter is keyed the relay RE202 switches on. The antenna tuner AT1500 gets 22V supply via J101 pin 7. The voltage at IC201 pin 6 and pin 7 is determined by R204, R205 and R206. These inputs form an over and under voltage protection. "Over voltage" shut down occurs at approx. 33.5V input. "Under voltage" shut down occurs at approx. 16.5V input.

Switching on PUII means that C207 can be charged by IC201 and create a soft start function at pin 15 to limit the peak current in the switch transistors and the output rectifier.

The IC201 has two outputs, pin 12 and pin 13, working as push-pull and being active low. The switch frequency is approx. 450 Hz, but the frequency of the internal sawtooth oscillator is approx. 900 Hz, determined by R207 and C206.



Regulation of the duty-cycle is done by varying the voltage at pin 4. This regulation signal to control the output current and output voltage is created in IC204.

Voltage supply for IC201 is regulated by means of R201 and D201.

The controlled square wave from the outputs of IC201 is led to the switch transistors T504 and T505 via the driver transistors T201 and T202 and the driver transformers TR202 and TR203. The diodes D206 - D209 clamp the over voltage transients from the driver transformers. The diodes D503 and D504 together with C501, R502, C502 and R503 protect the switch transistors against transients and unwanted oscillations. C503 reduces the ripple to the input filter.

The output voltage is rectified in D505. R504, C504 and R505 protect against unwanted oscillations and transients. The choke L503 is an energy reservoir. Together with C101 - C106 it is smoothing the output current.

The output voltage of 38V is regulated by IC204a. The reference voltage is made by D213. Adjustment is done with R259. If the output voltage increases, pin 1 will go low. Via OC201, IC201 pin 4 is pulled down and this reduces the duty-cycle and thus the output voltage. R266 has to be connected to ground to get 38V. For supply reduction to the transmitter, R266 is released from ground via the thermal protection unit in T1130 and the output voltage is approx. 30V.

A current limiter is performed by IC204b. R101 is the current sensor and is made of konstantan wire. If the current exceeds the level determined by R243, the output pin 7 goes high and turns on T207, which again pulls down the reference voltage for IC204a. This means that the output voltage to the transmitter will be reduced.

The current limiter is made slow with C226 to prevent the variation from the modulation of the transmitter. It cannot protect the output transistors or rectifier against short circuit of the output.

IC206 delivers a regulated 8V supply for the voltage regulator and current limiter circuit.

The 28V output is regulated by IC205 and is adjusted with R271. Transistor T208 turns on and the current flows through L504 to C231 and the load. The voltage increases at pin 4 and IC205 turns off T208. The current flows continuously in L504 and back through D214. The voltage will decrease at pin 4 and IC205 turns on T208 again. The regulator is then self oscillating. R268 forms a current limiter.

### 3.4. BLOWER CONVERTER

When PUI is started up the oscillator IC301 is always running. The output stage and also the blowers are switched on/off by means of OC301 and IC303.

The supply for the blower converter control circuit is regulated to 12V by means of R322 and D301.

The frequency of the oscillator IC301 is 120 Hz and is determined by means of IC301, C303, R305, R306 and R307. The frequency is adjusted with R305. The output pulses from IC301 pin 3 are led to IC303 pin 2 and to T303 which inverts the signal before it is led to IC302 pin 3, which produces a square wave signal of 60 Hz to the output stage.

In order to avoid the simultaneous conducting of all four output transistors T506 - T509, a dead time is performed with IC303, which pulls down the base of T304 and T305 via D302 and D303. This will block the output stage.

If OC301 is not activated, IC303 pin 4 is grounded via R313 and the dead time is 100 % and then the output stage is off. If IC303 pin 4 is pulled high via OC301, the output pulse from IC303 pin 3 is 7.5 ms, which is adjusted with R311 and the blowers are running.

The output stage is a bridge coupled push-pull stage and consists of four Darlington power transistors T506 - T509 driven by the transistors T304 and T305.

By means of OC301 the blowers can be switched on in three ways. OC301 is always biased with 22V from PUI.

If temperature in the whole power supply exceeds 55°C, the thermal breaker TB501 is switched on and starts the blowers until the temperature is approx. 40°C.

When transmitter is keyed, diode D306 is grounded via handset key and the blowers are running.

The temperature protection unit in the transmitter unit breaks the connection between +22V and supply block terminal at J102. This turns off T301 which again turns on OC301 and thus also the blowers.

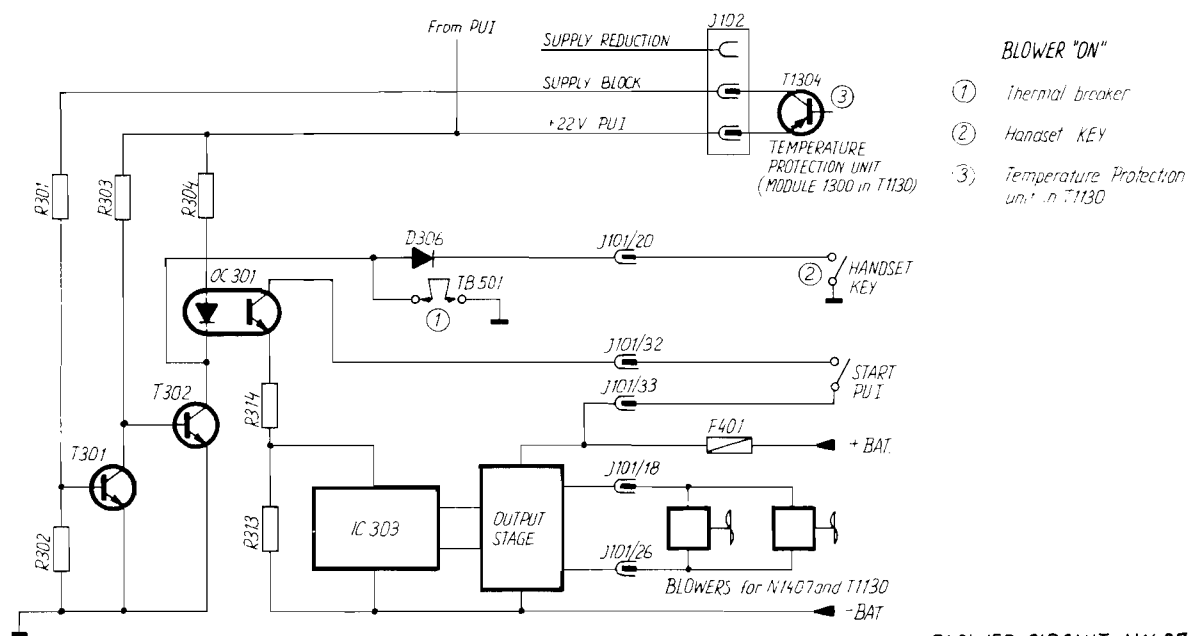

BLOWER CIRCUIT N1407

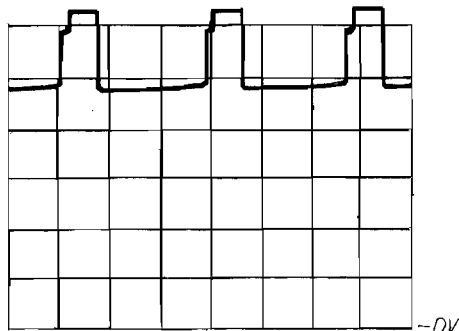
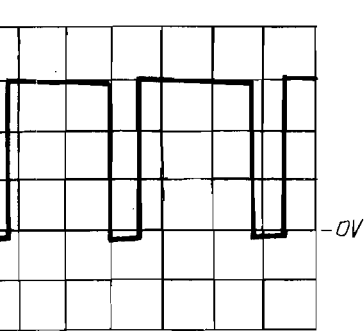

Y-5V/DIV  
X-50µsec/DIV  
Ref.:

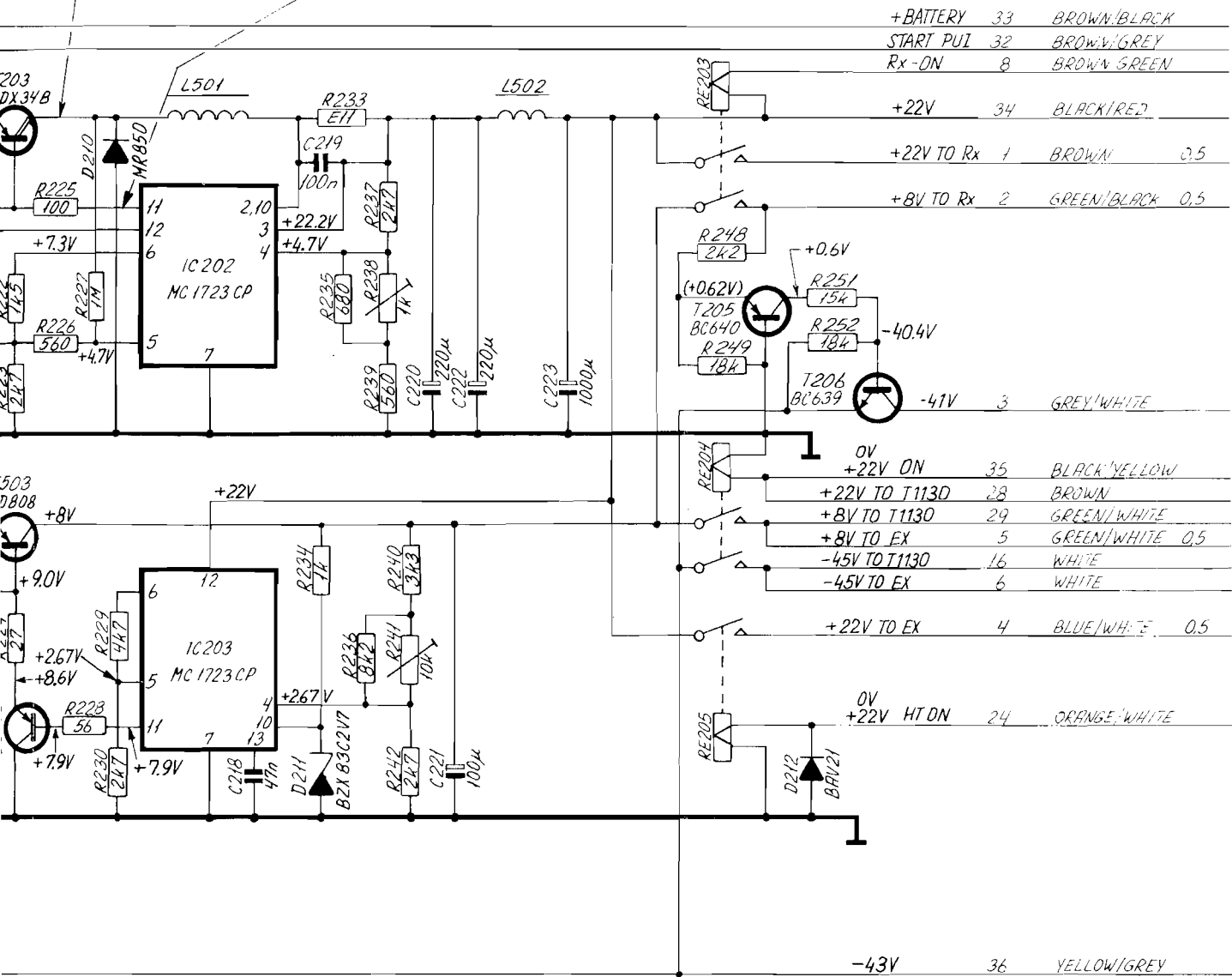

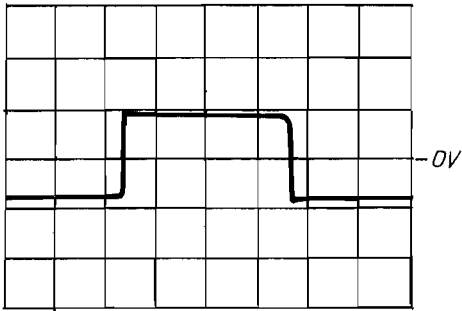

Y= 1V/DIV  
X= 0.5msec/DIV  
Ref: - BATT.

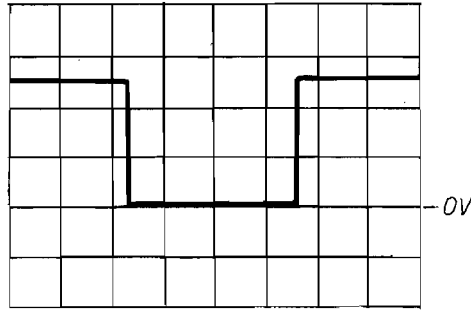

Y= 20V/DIV  
X= 0.5msec/DIV  
Ref: - BATT.

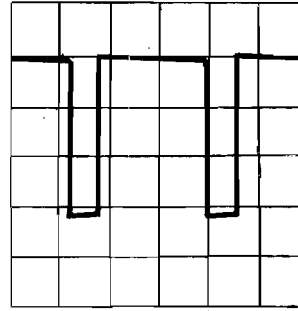

Y= 10V/DIV  
X= 50μsec/DIV  
Ref: -

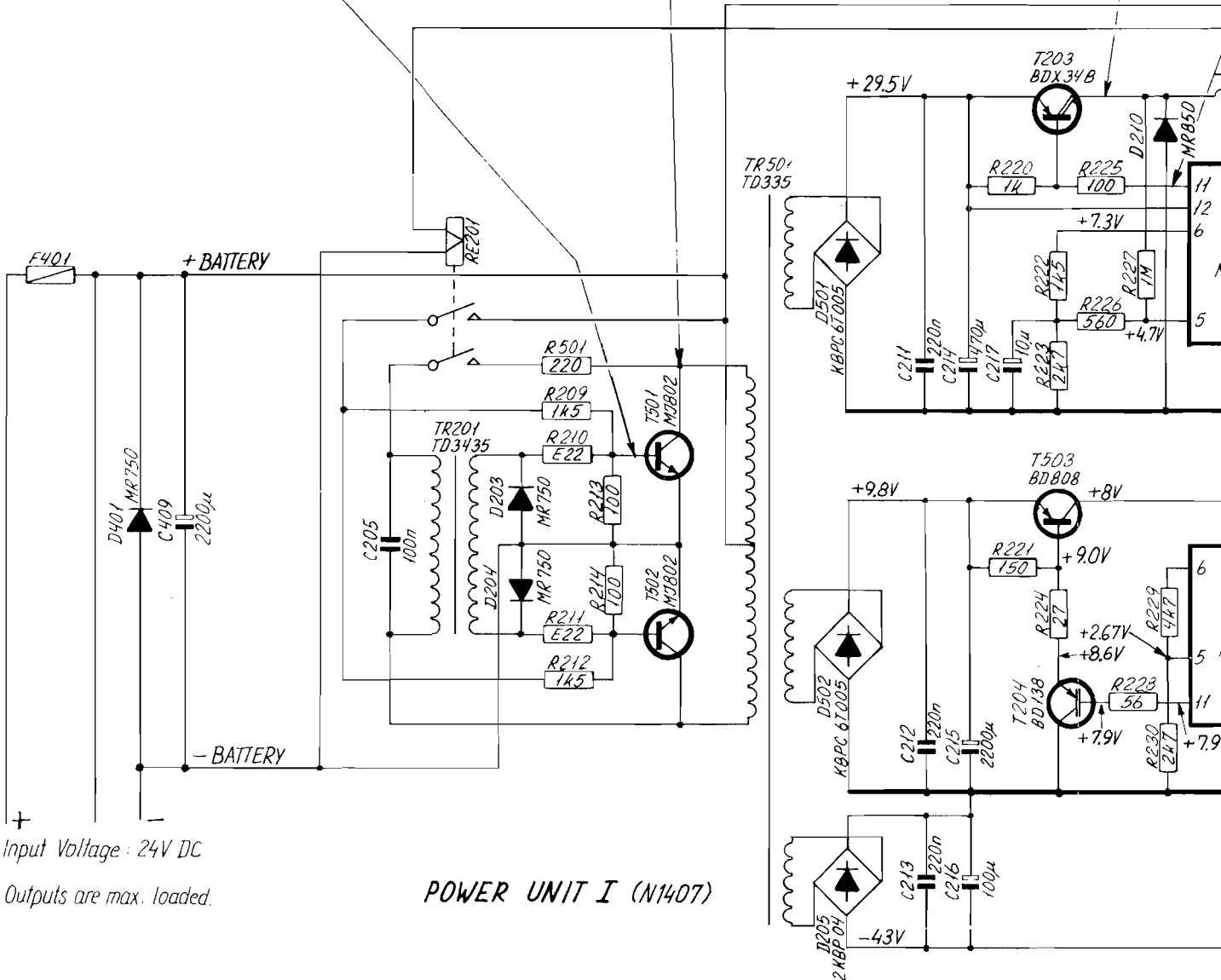

Input Voltage: 24V DC

Outputs are max. loaded.

POWER UNIT I (N1407)

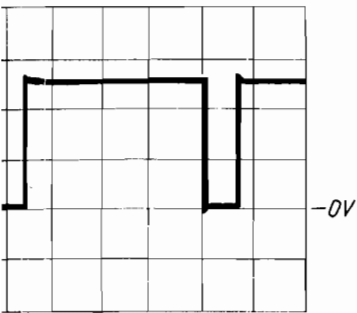

10V/DIV  
10µs

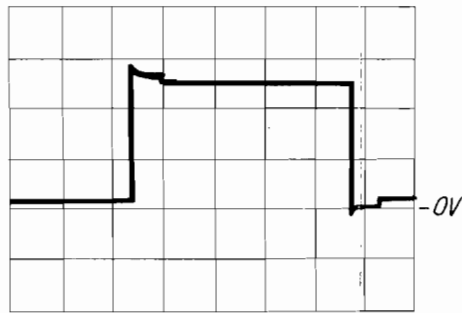

Y= 10V/DIV  
X= 2msec/DIV  
Ref. = -Batt.

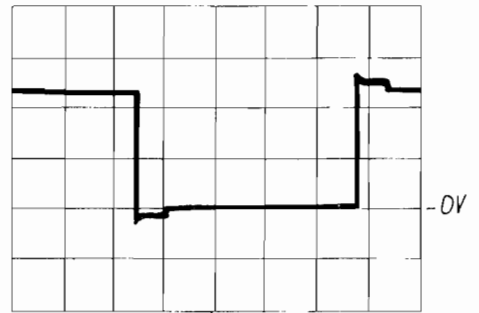

Y= 10V/DIV  
X= 2msec/DIV  
Ref. = -Batt.

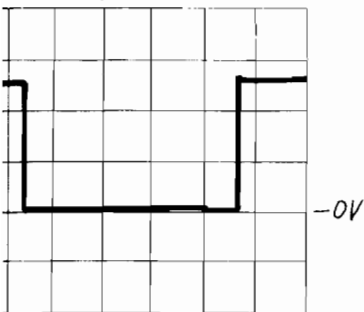
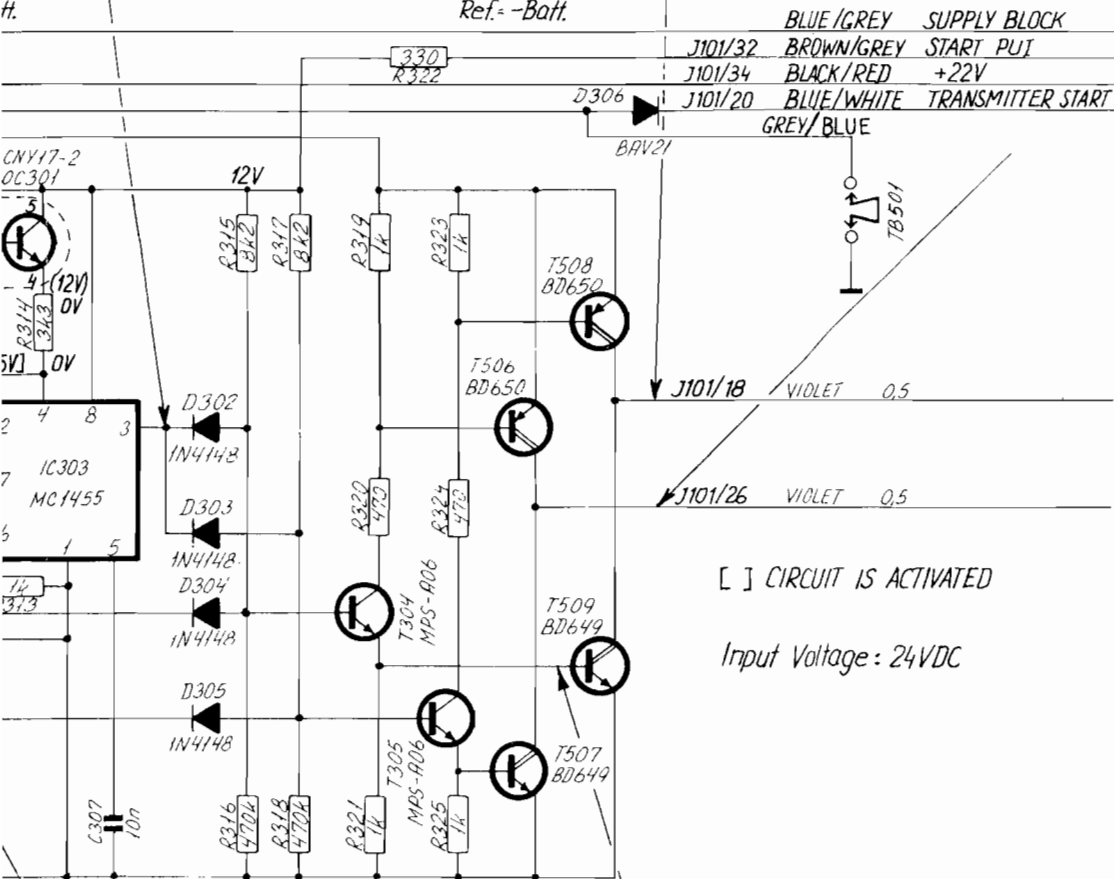

10V/DIV  
10µs

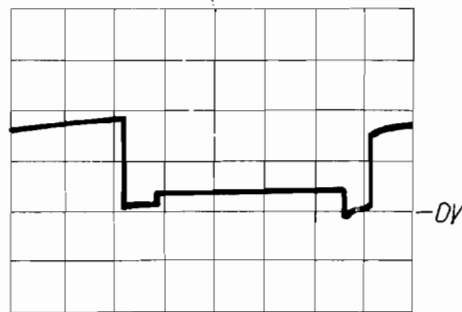

Y= 1V/DIV  
X= 2msec/DIV  
Ref. = -Batt.

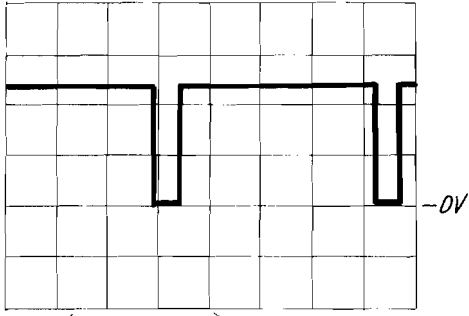

Y= 5V/DIV  
X= 2msec/DIV  
Ref: - Batt.

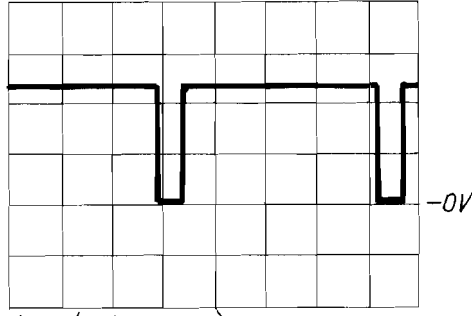

Y= 5V/DIV  
X= 2msec/DIV  
Ref: - Batt.

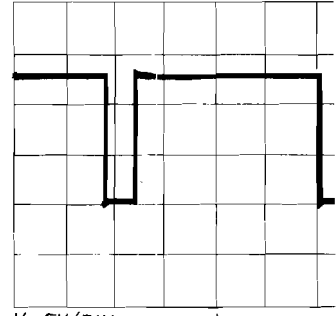

Y= 5V/DIV  
X= 2msec/DIV  
Ref: - Batt.

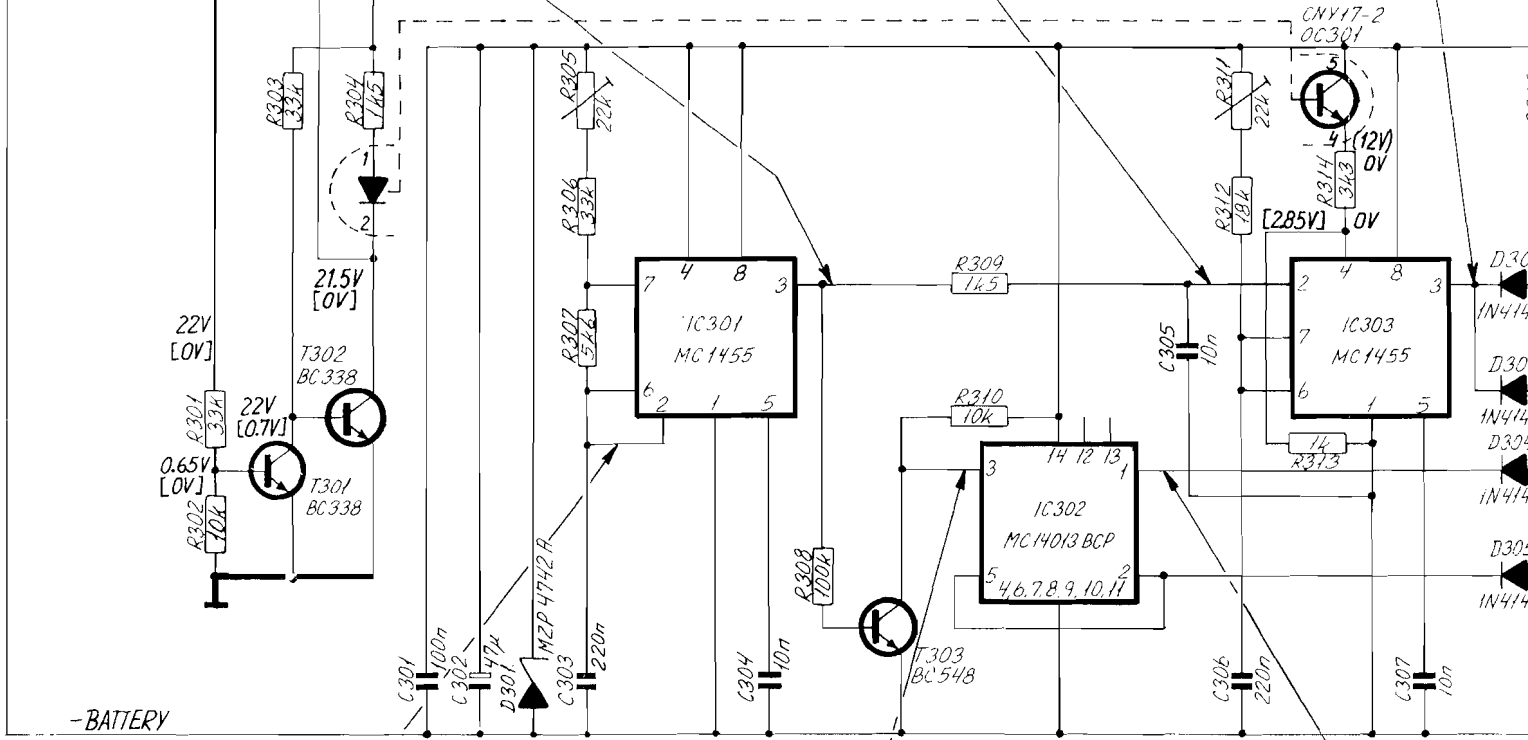

BLOWER CONVERTER (N1407)



Y= 2V/DIV  
X= 2msec/DIV  
Ref: - Batt.

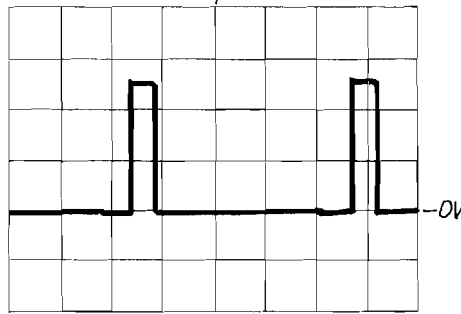

Y= 5V/DIV  
X= 2msec/DIV  
Ref: - Batt.

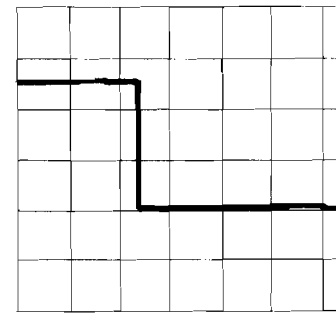

Y= 5V/DIV  
X= 2msec/DIV  
Ref: - Batt.

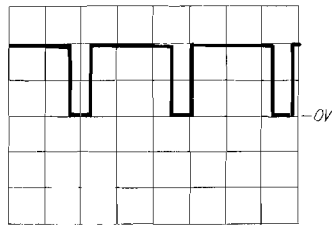
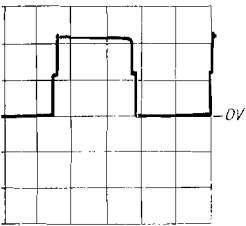

Y=20V/DIV  
X=0.1msec/DIV  
Ref.  $\rightarrow$

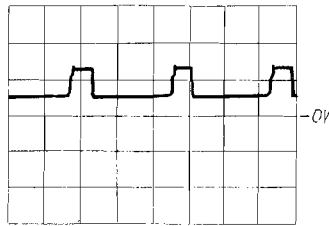

Y=20V/DIV  
X=0.1msec/DIV  
Ref.  $\rightarrow$

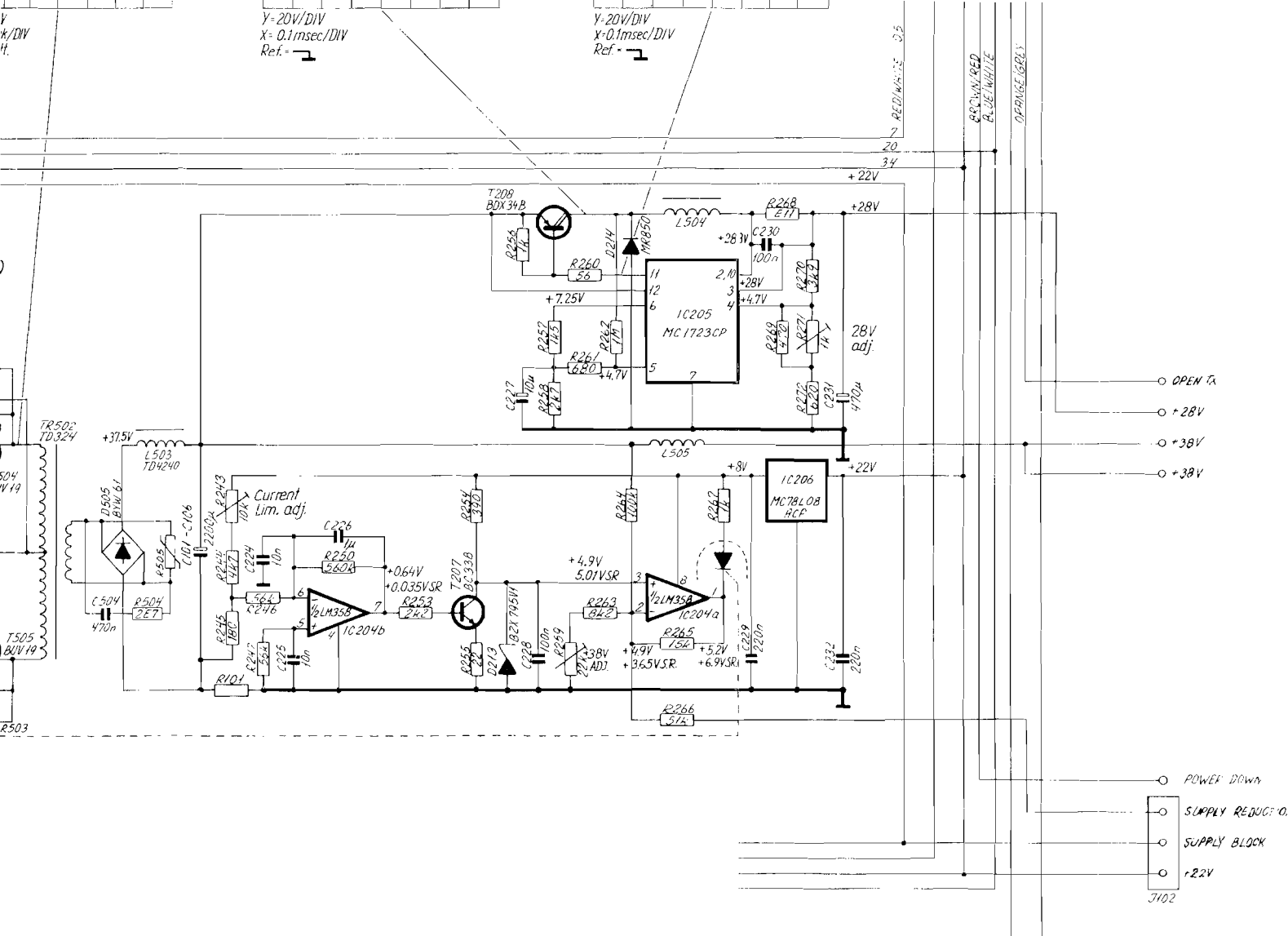

RED/WHITE  
BLUE/WHITE  
ORANGE/GREEN

- OPEN FA
- +28V
- +38V
- +38V
- POWER DOWN
- SUPPLY REDUCT. 0.
- SUPPLY BLOCK
- +22V

J102

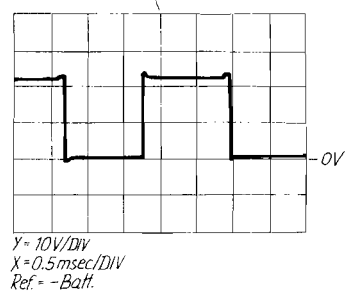
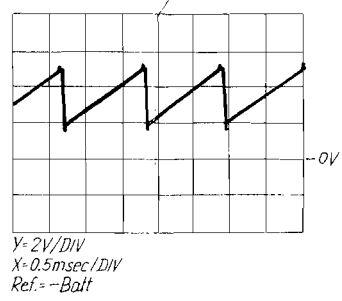
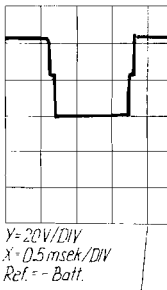
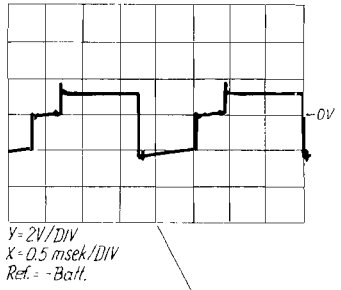
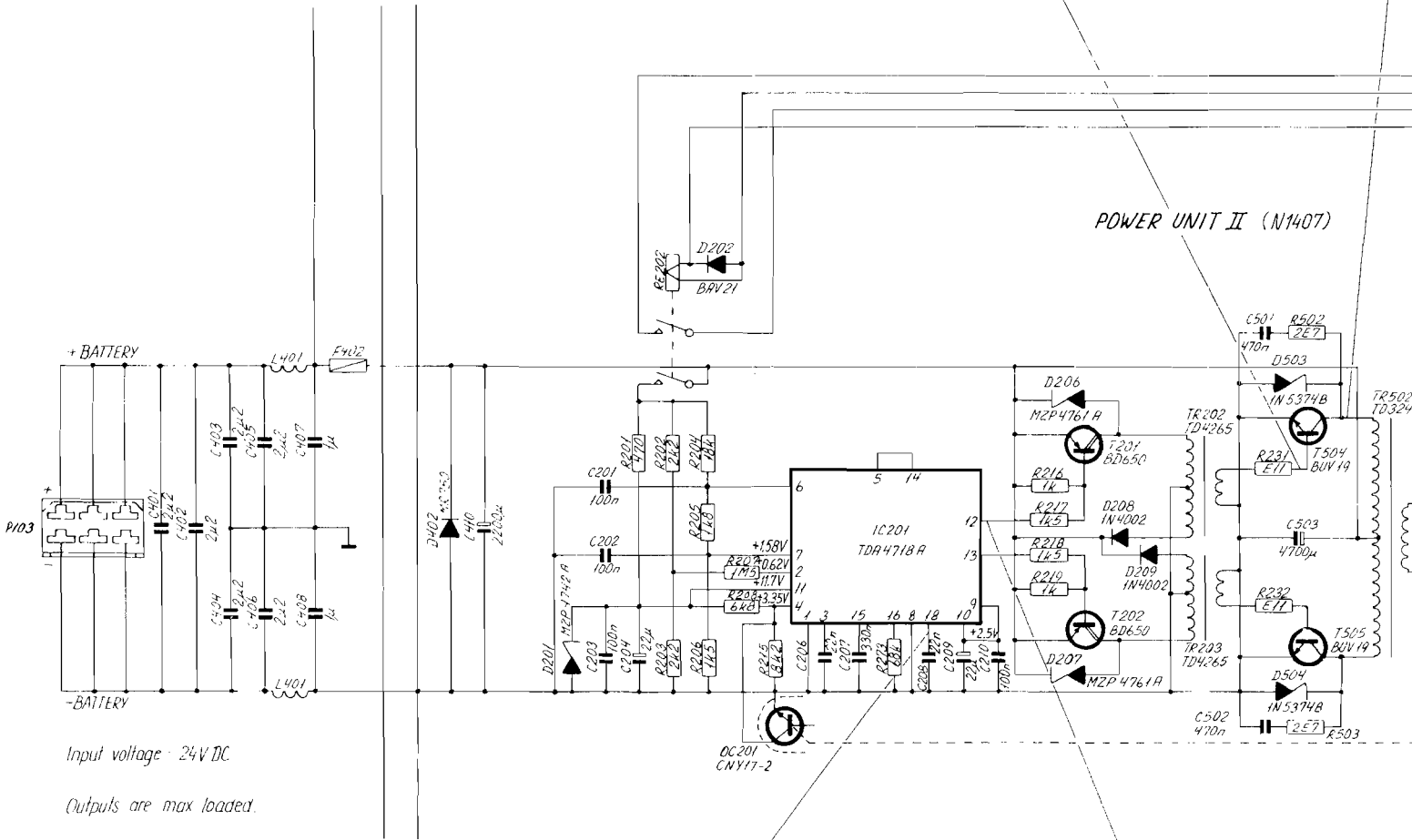



CONTENTS:

- 4. COMPONENT LOCATIONS:
  - 4.1 CAPACITOR UNIT (MODULE 100)
  - 4.2 PUI AND PUII CONTROL UNIT (MODULE 200)
  - 4.3 BLOWER CONVERTER (MODULE 300)
  - 4.4 INPUT FILTER AND FUSES (MODULE 400)
  - 4.5 CHASSIS MOUNTING (MODULE 500)
  - 4.9 DISASSEMBLING FROM T1130
  - 4.10 MAIN DIAGRAM

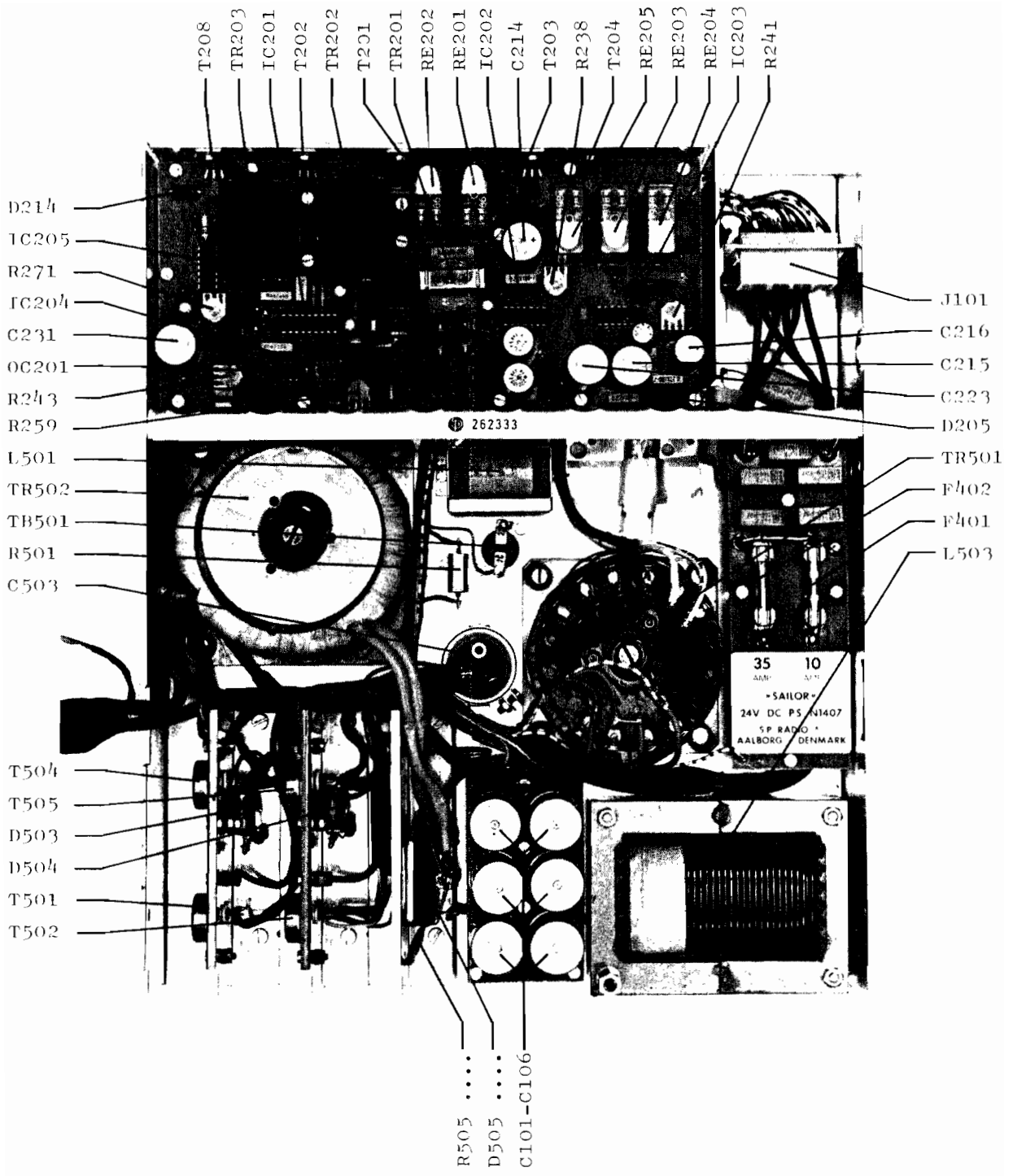

Komponent location

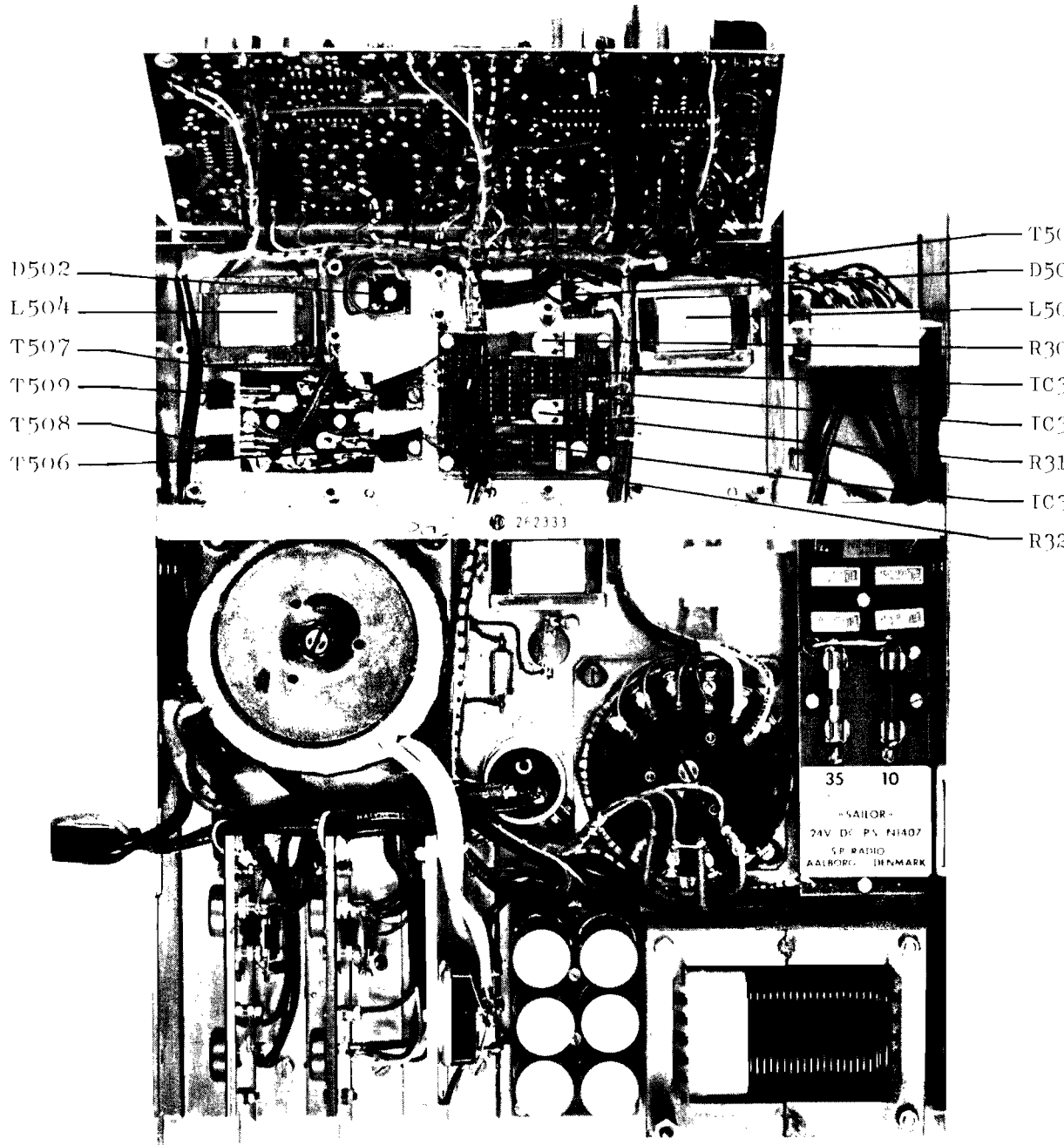

D502  
L504  
T507  
T509  
T508  
T506

T50  
D50  
L50  
R30  
IC3  
IC3  
R3L  
IC3  
R32

V1407

35 10  
SAILOR  
24V DC PS. N1407  
SE RADIO  
AALBORG - DENMARK

242333

4.1. CAPACITOR UNIT (MODULE 100)

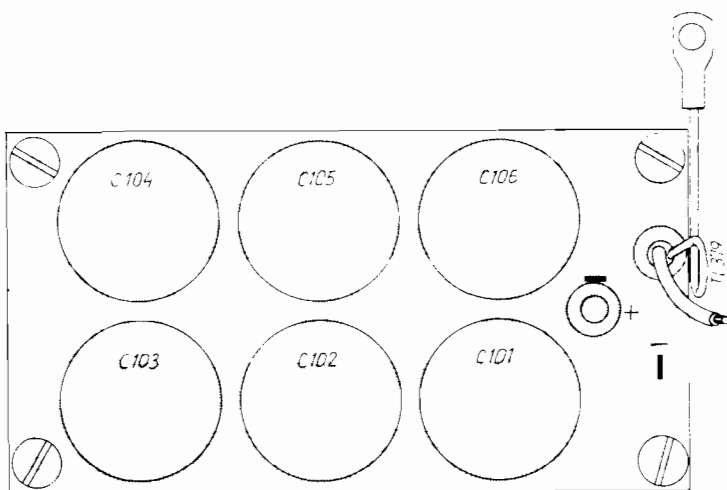

40

## WIRECOLOURS

- 0 = BLACK
- 1 = BROWN
- 2 = RED
- 3 = ORANGE
- 4 = YELLOW
- 5 = GREEN
- 6 = BLUE
- 7 = VIOLET
- 8 = GREY
- 9 = WHITE

Ex. : BROWN/WHITE =

# 4.2. PU I AND PU II CONTROL UNIT (MODULE 200)

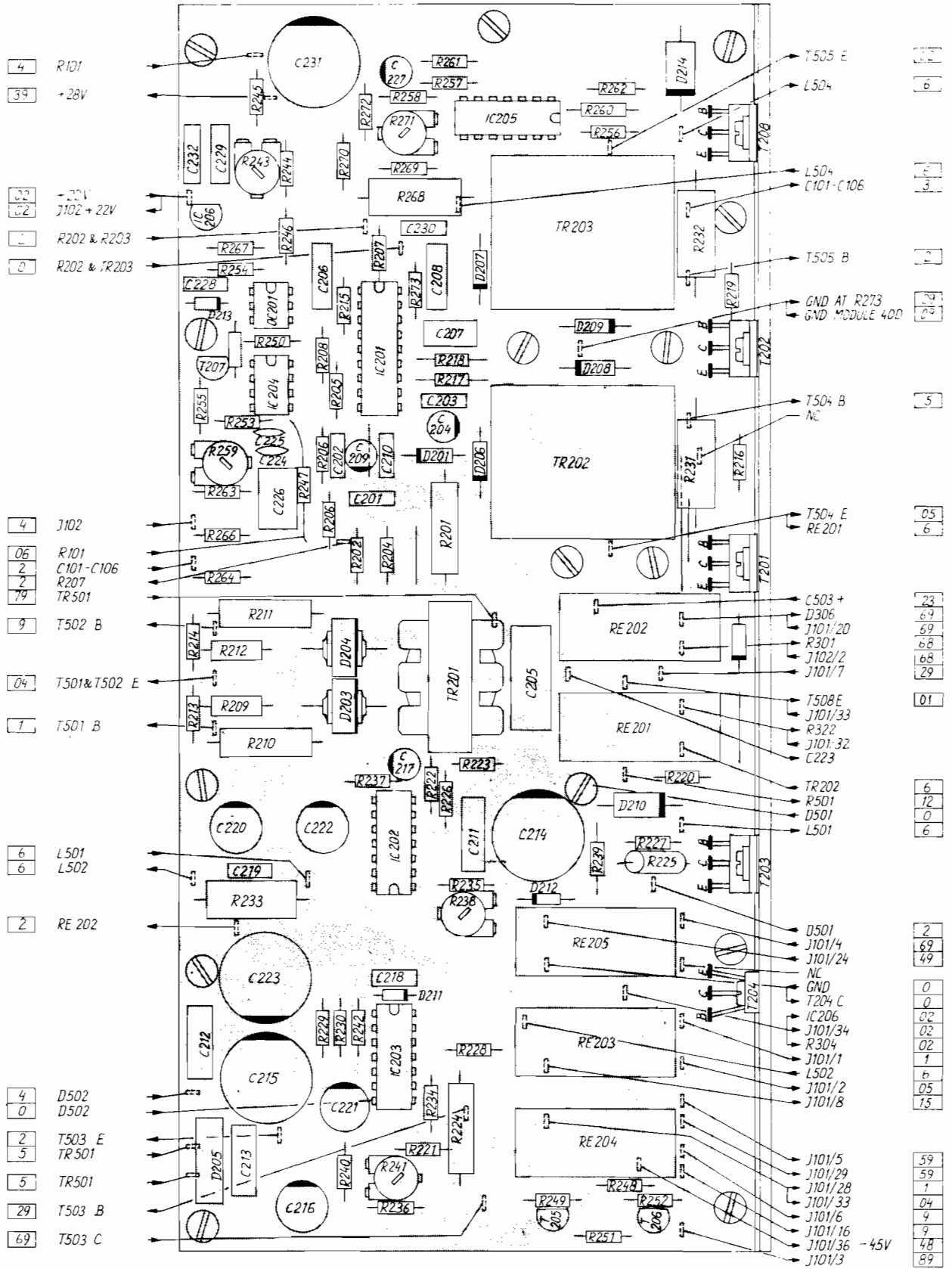

- 4 R101
- 39 +28V
- 05 +20V
- 02 J102 +22V
- 1 R202 & R203
- 0 R202 & TR203
- 4 J102
- 06 R101
- 2 C101-C106
- 7 R207
- 79 TR501
- 9 T502 B
- 04 T501 & T502 E
- 7 T501 B
- 6 L501
- 6 L502
- 2 RE 202
- 4 D502
- 0 D502
- 2 T503 E
- 5 TR501
- 5 TR501
- 29 T503 B
- 69 T503 C

- T505 E
- L504
- L504
- C101-C106
- T505 B
- GND AT R273
- GND MODULE 400
- T504 B
- NC
- T504 E
- RE 201
- C503 +
- D306
- J101/20
- R301
- J102/2
- J101/7
- T508 E
- J101/33
- R322
- J101/32
- C223
- TR202
- R501
- D501
- L501
- D210
- D501
- L501
- D501
- J101/4
- J101/24
- NC
- GND
- T204 C
- IC206
- R304
- J101/1
- L502
- J101/2
- J101/8
- J101/5
- J101/29
- J101/28
- J101/33
- J101/6
- J101/16
- J101/36
- J101/3
- 45V

## WIRECOLOURS

- 0 = BLACK
- 1 = BROWN
- 2 = RED
- 3 = ORANGE
- 4 = YELLOW
- 5 = GREEN
- 6 = BLUE
- 7 = VIOLET
- 8 = GREY
- 9 = WHITE

Ex. : BROWN/WHITE =

### 4.3. BLOWER CONVERTER (MODULE 300)

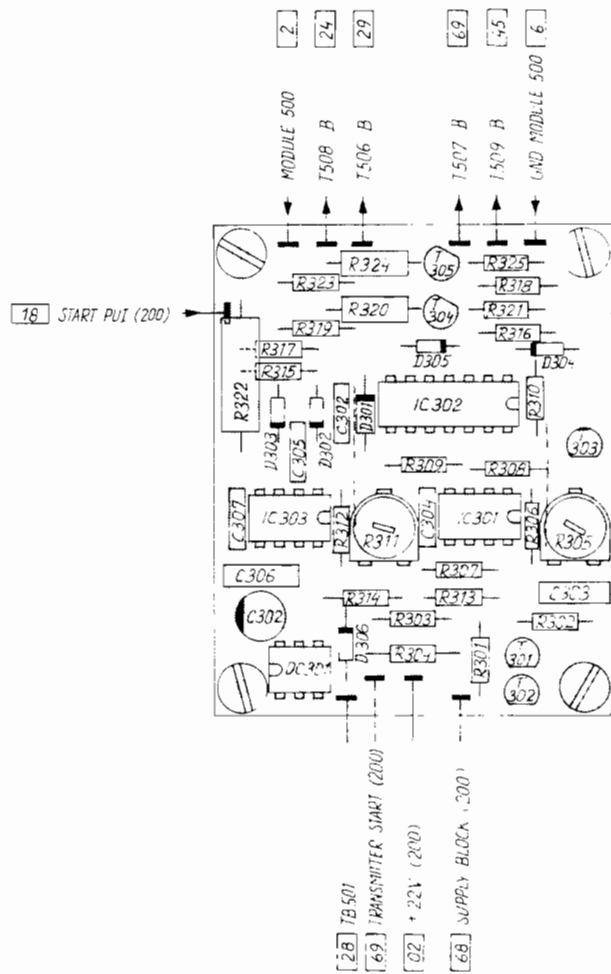

### 4.4. INPUT FILTER AND FUSES (MODULE 400)

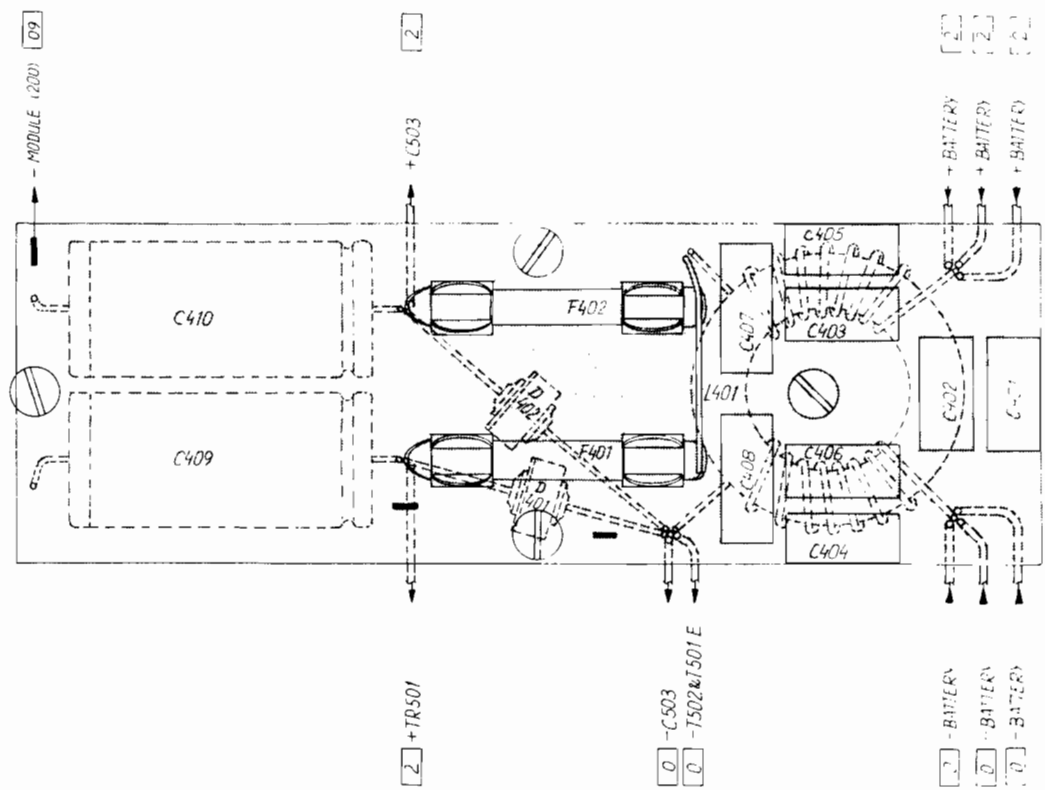



## WIRECOLOURS

- 0 = BLACK
- 1 = BROWN
- 2 = RED
- 3 = ORANGE
- 4 = YELLOW
- 5 = GREEN
- 6 = BLUE
- 7 = VIOLET
- 8 = GREY
- 9 = WHITE

Ex.: BROWN/WHITE =

7 4 2498

# 4.5. CHASSIS MOUNTING (MODULE 500)

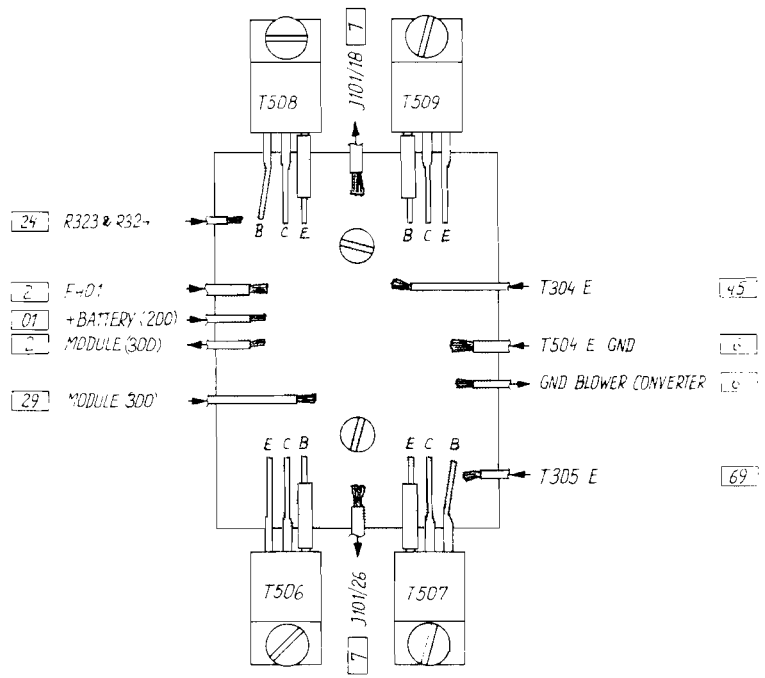

## WIRECOLOURS

- 0 = BLACK
- 1 = BROWN
- 2 = RED
- 3 = ORANGE
- 4 = YELLOW
- 5 = GREEN
- 6 = BLUE
- 7 = VIOLET
- 8 = GREY
- 9 = WHITE

Ex. : BROWN/WHITE =

33497 4  
6672  
2498

# 4.9. DISASSEMBLING FROM T1130

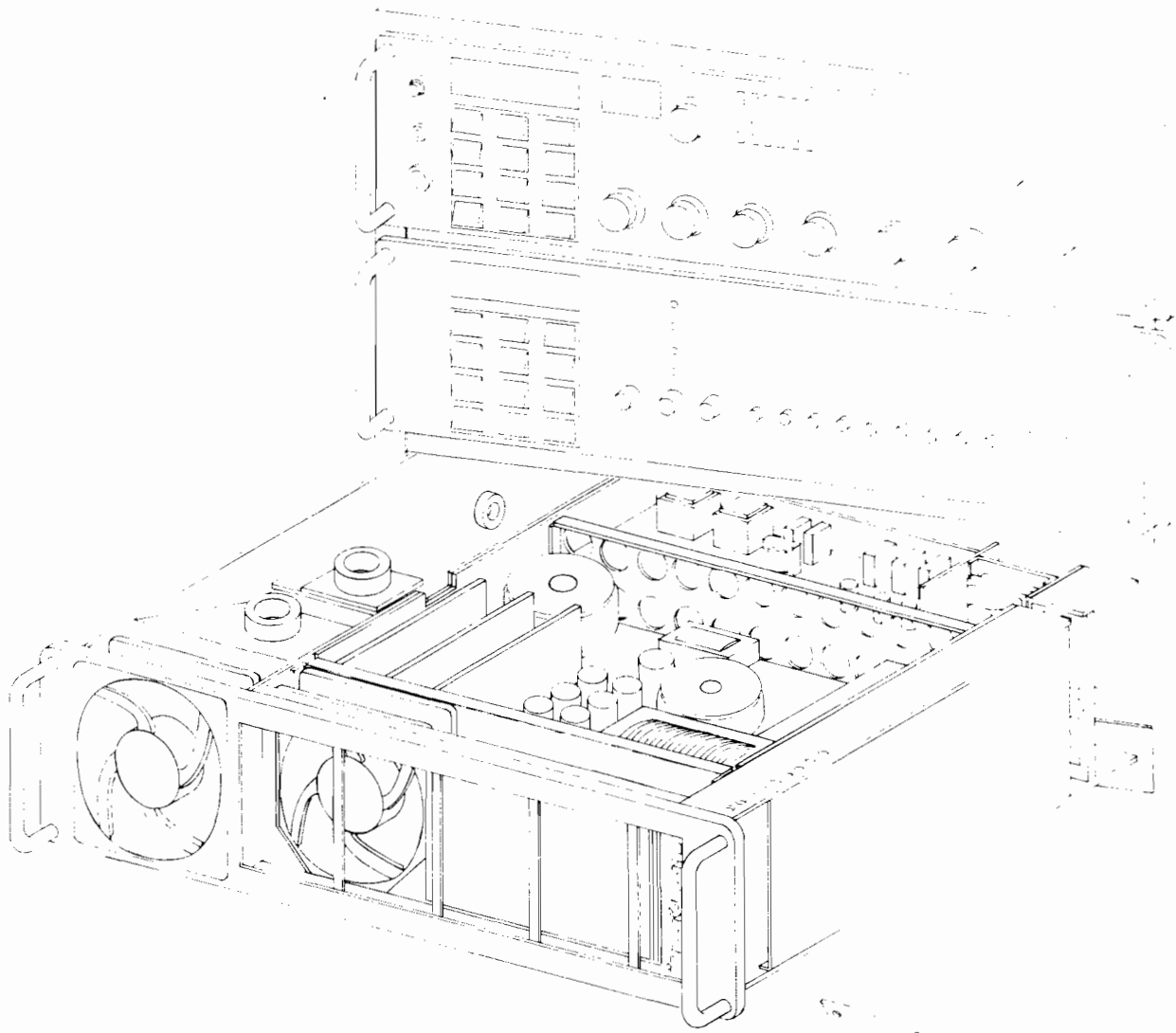

- \* Copper coloured screws must be removed to release module 100
- \*\* Remove screws to release power supply from T1130 chassis

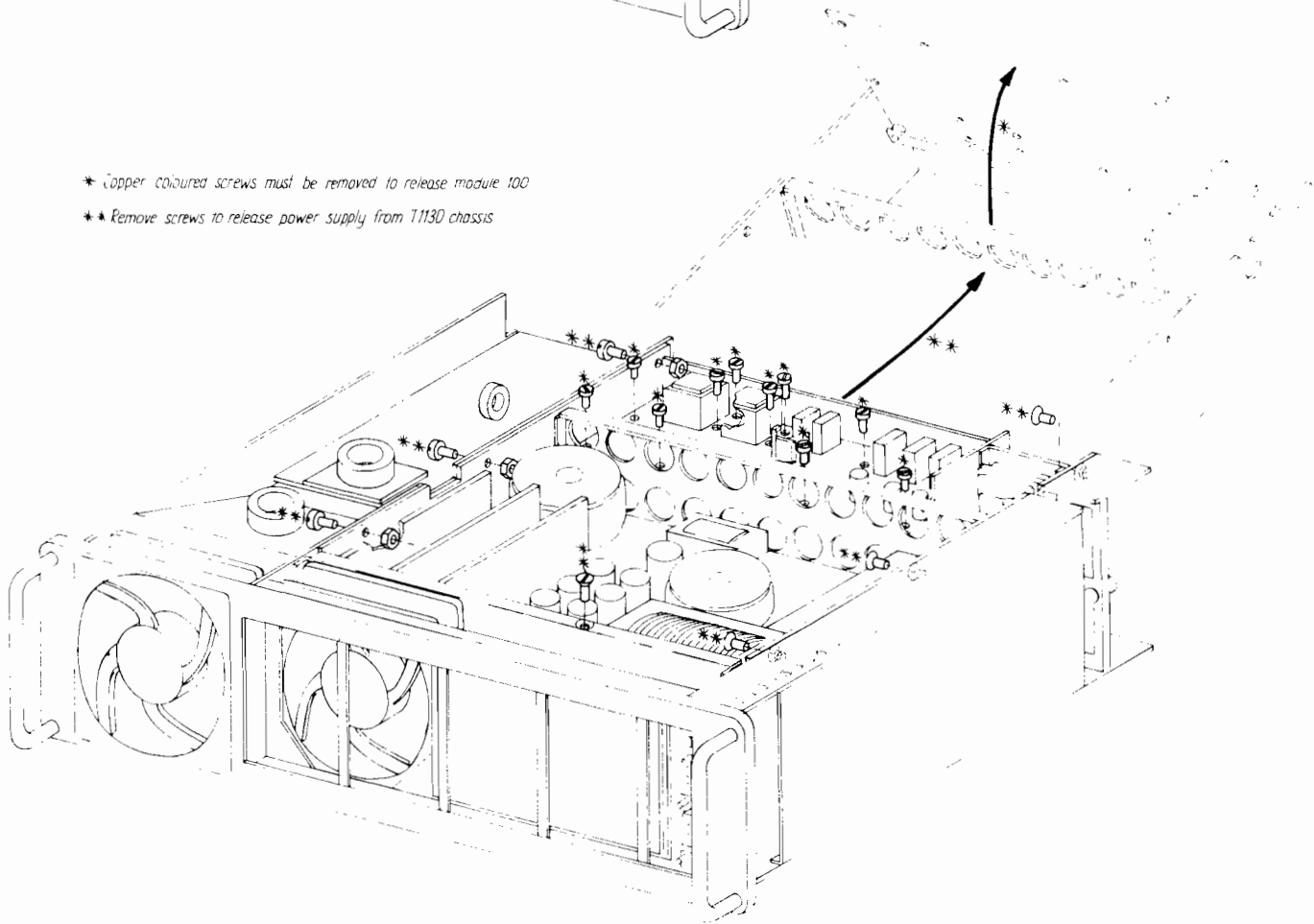

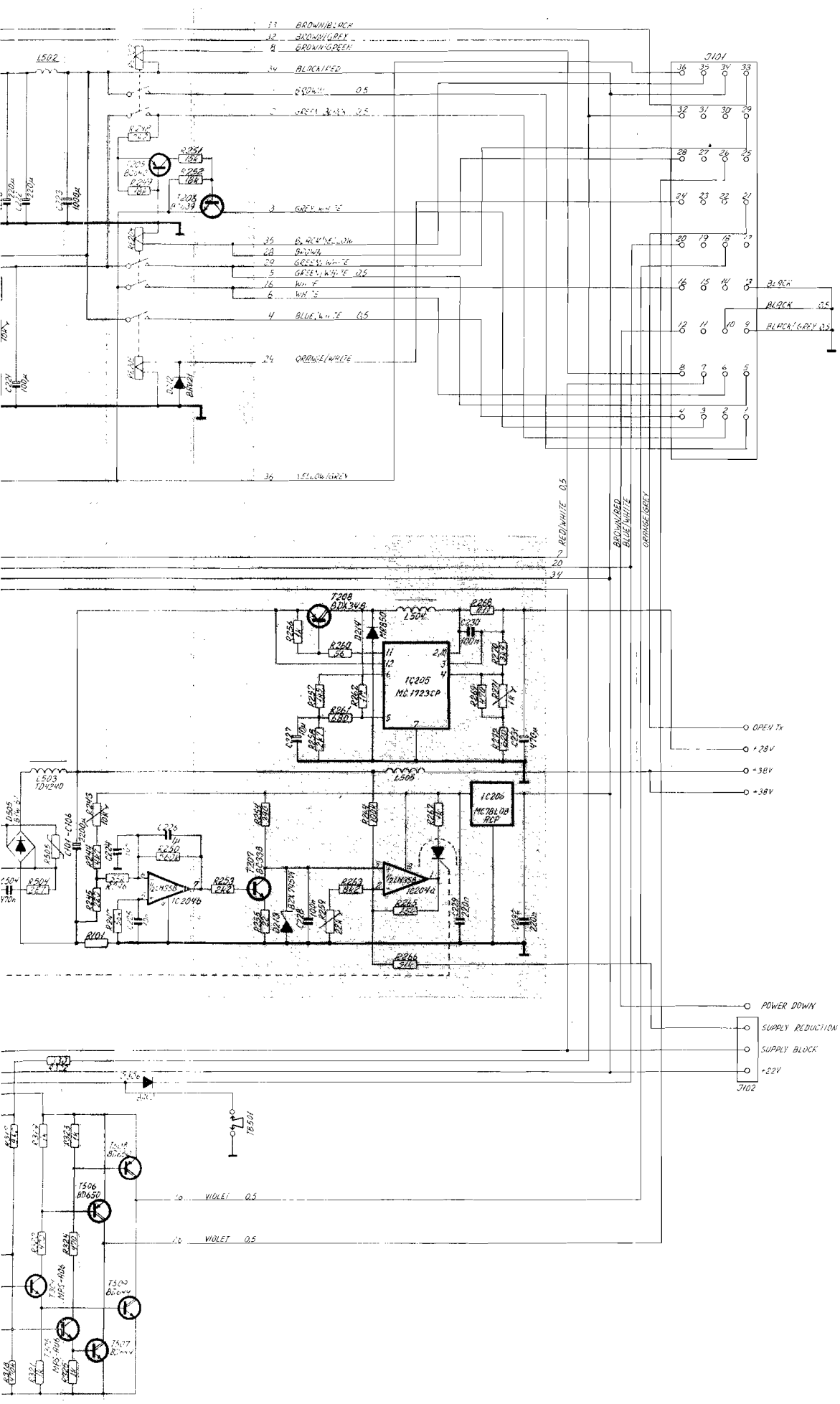

- 1 22V TO EX
- 2 8V TO EX
- 3 -45V TO EX
- 4 22V TO EX
- 5 8V EX
- 6 -45V TO EX
- 7 22V AT 1500
- 8 R+ ON
- 9 GROUND EX
- 10 GROUND EX
- 11
- 12 POWER DOWN
- 13 GROUND AT 255
- 14
- 15
- 16 -45V TO T1130
- 17
- 18 BLOWER
- 19
- 20 TRANSMITTER SIBEL
- 21 OPEN TX
- 22
- 23
- 24 H+ ON
- 25
- 26 BLOWER
- 27
- 28 22V T1130
- 29 8V T1130
- 30
- 31
- 32 SIBEL P.O.T
- 33 + BATTERY
- 34 22V AT 1235
- 35 ON
- 36 -45V

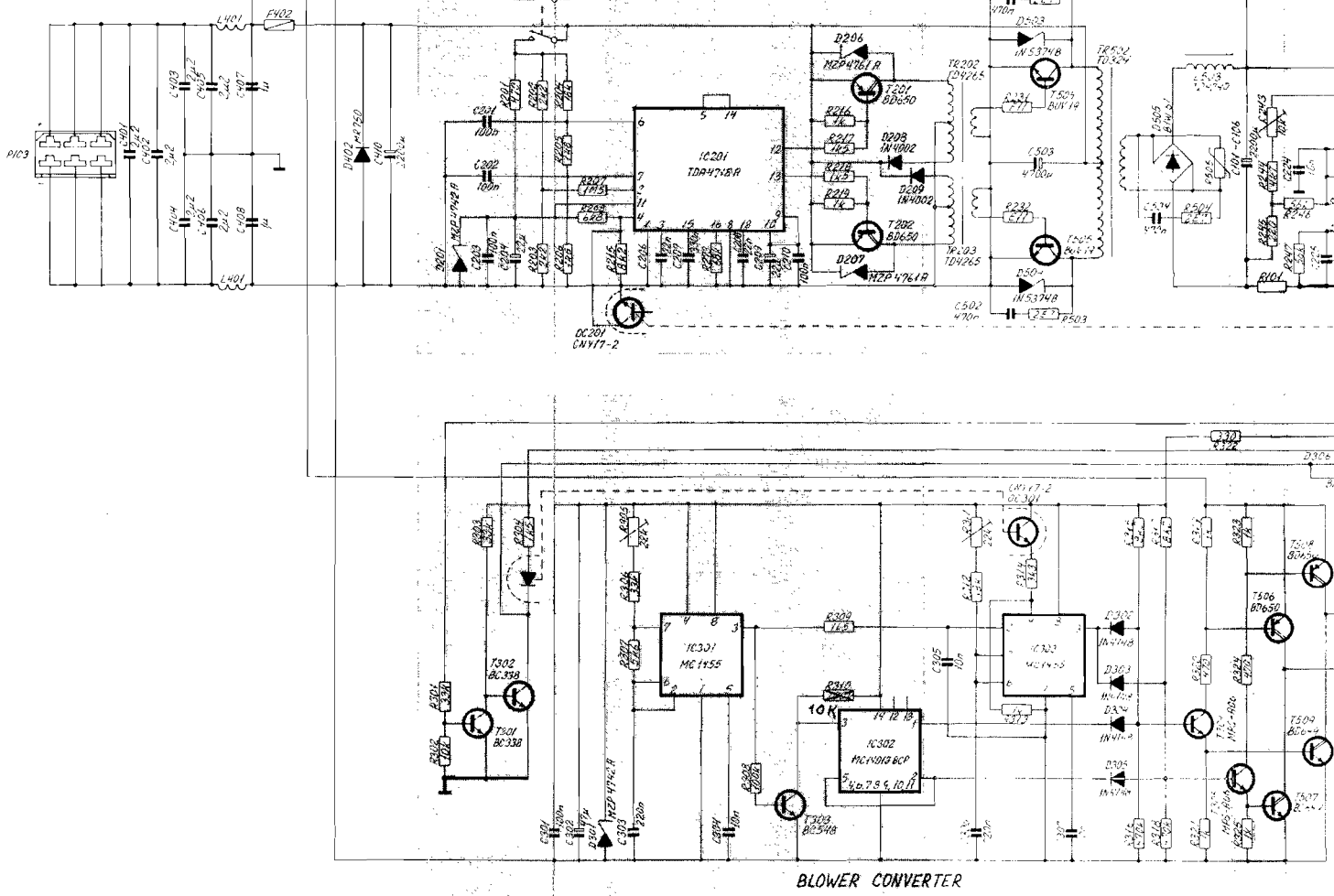
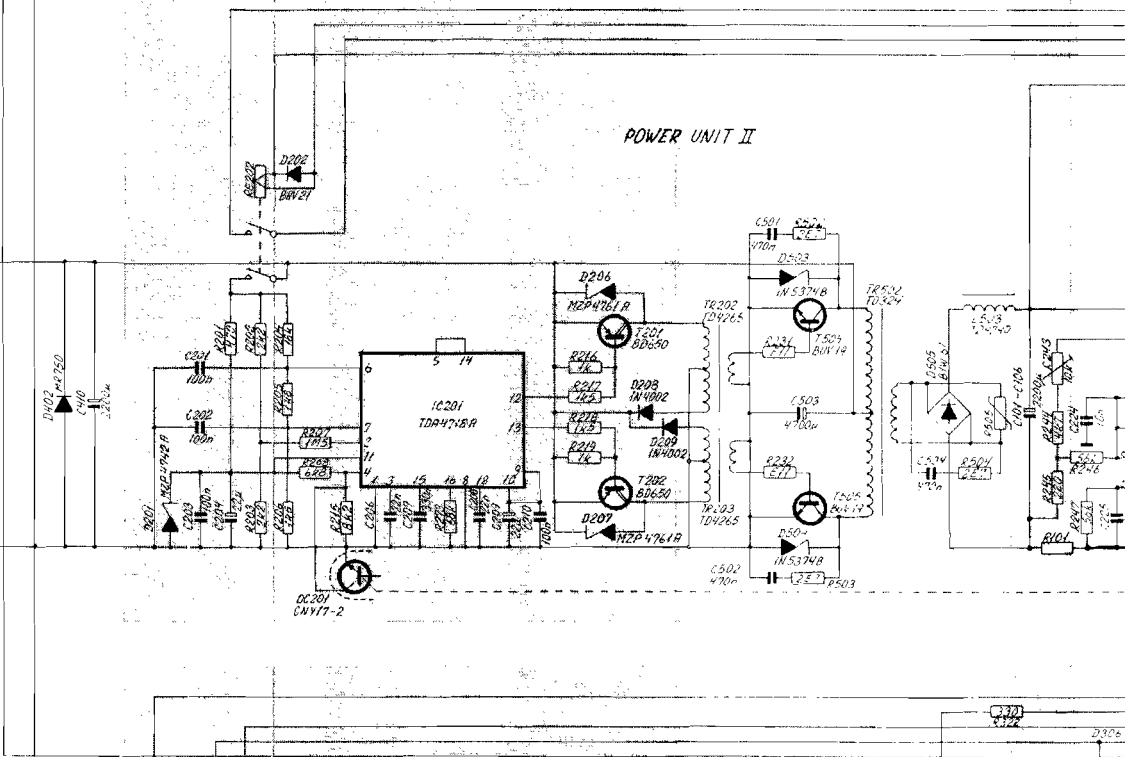
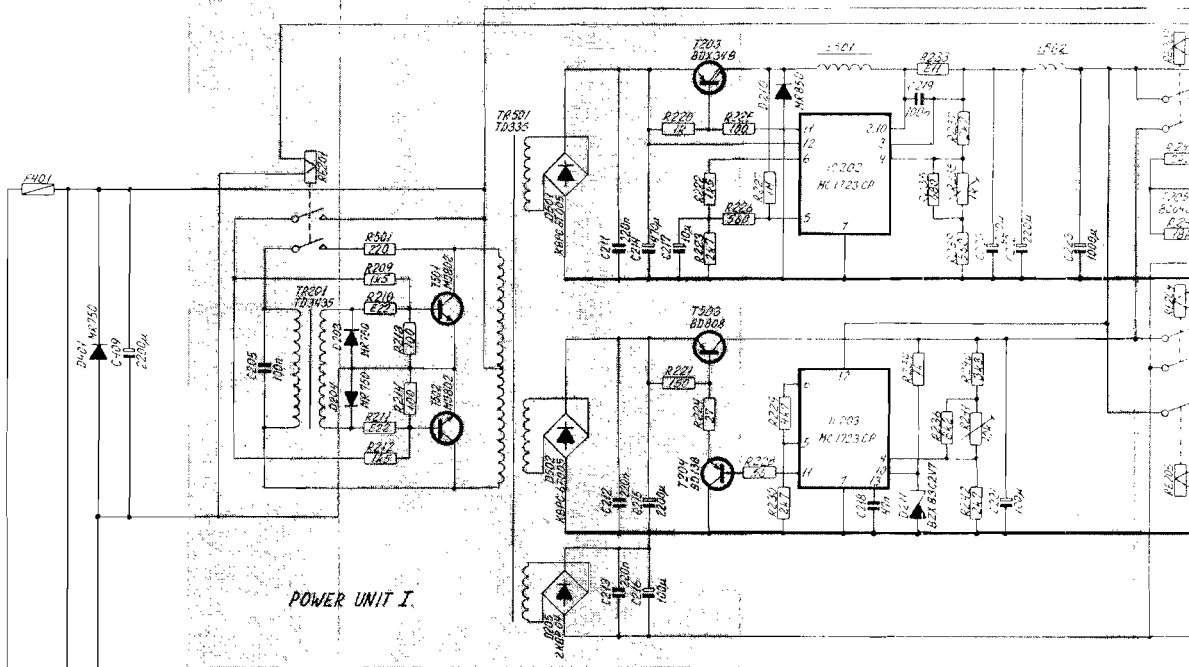

CONTENTS:

5 PART LISTS

MI407

POSITION	DESCRIPTION	MANUFACTURER	TYPE	S.P. NUMB	
	CAPACITOR UNIT	MODULE 1/100	ESPERA	PRINT NR. 5-U-23224B	608338
C101	CAPACITOR ELECTROLYTIC	2200uF -10/+50% 40V	* ERO	EGD EG 03 MG 422 G	14.730
C102	CAPACITOR ELECTROLYTIC	2200uF -10/+50% 40V	* ERO	EGD EG 03 MG 422 G	14.730
C103	CAPACITOR ELECTROLYTIC	2200uF -10/+50% 40V	* ERO	EGD EG 03 MG 422 G	14.730
C104	CAPACITOR ELECTROLYTIC	2200uF -10/+50% 40V	* ERO	EGD EG 03 MG 422 G	14.730
C105	CAPACITOR ELECTROLYTIC	2200uF -10/+50% 40V	* ERO	EGD EG 03 MG 422 G	14.730
C106	CAPACITOR ELECTROLYTIC	2200uF -10/+50% 40V	* ERO	EGD EG 03 MG 422 G	14.730
R101	RESISTOR	TL379	ESPERA	6-U-23757	400379

POSITION	DESCRIPTION	MANUFACTURER	TYPE	S.P. NUMB	
	POWER UNIT I & II	MODULE 2/200	ESPERA	PRINT NR 5-U-23061A	608338
C201	CAPACITOR MKT	100nF 10% 100V	*SIEMENS	B32520-A1104-K	11.219
C202	CAPACITOR MKT	100nF 10% 100V	*SIEMENS	B32520-A1104-K	11.219
C203	CAPACITOR MKT	100nF 10% 100V	*SIEMENS	B32520-A1104-K	11.219
C204	CAPACITOR ELECTROLYTIC	22uF 20% 25V	* ERO	EKI 00 AA 222 E	14.514
C205	CAPACITOR MKT	0.1uF 10% 400V	*ERO	MKT1822	11.075
C206	CAPACITOR MKT	22nF 10% 400V	*ERO	MKT1822	11.075
C207	CAPACITOR MKT	330nF 10% 63V	* ERO	MKT1818	11.075
C208	CAPACITOR MKT	22nF 10% 400V	*ERO	MKT1822	11.075
C209	CAPACITOR ELECTROLYTIC	22uF 20% 25V	* ERO	EKI 00 AA 222 E	14.514
C210	CAPACITOR MKT	100nF 10% 100V	*SIEMENS	B32520-A1104-K	11.219
C211	CAPACITOR POLYESTER	0.22uF 10% 100V	*ERO	MKT1822	11.075
C212	CAPACITOR POLYESTER	0.22uF 10% 100V	*ERO	MKT1822	11.075
C213	CAPACITOR POLYESTER	0.22uF 10% 100V	*ERO	MKT1822	11.075
C214	CAPACITOR ELECTROLYTIC	470uF -20/+30% 63V	**PHILIPS	2222 035 68471	14.604
C215	CAPACITOR ELECTROLYTIC	2200uF -10/+50% 16V	ERO	EKM 00 JG 422 D	14.711
C216	CAPACITOR ELECTROLYTIC	100uF -10/+50% 63V	ERO	EKM 00 DE 310 J	14.620
C217	CAPACITOR ELECTROLYTIC	10uF 20% 35V	* ERO	EKI 00 AA 210 F	14.512
C218	CAPACITOR MKT	47nF 10% 250V	SIEMENS	B32510-D3473-K000	11.303
C219	CAPACITOR MKT	100nF 10% 100V	*SIEMENS	B32520-A1104-K	11.219
C220	CAPACITOR ELECTROLYTIC	220uF -10/+50% 25V	*ERO	EKR	14.770
C221	CAPACITOR ELECTROLYTIC	100uF -10/+50% 25V	ERO	EKM 00 CC 310 E	14.610
C222	CAPACITOR ELECTROLYTIC	220uF -10/+50% 25V	*ERO	EKR	14.770
C223	CAPACITOR ELECTROLYTIC	1000uF -10/+50% 25V	ERO	EKM 00 JG 410 E	14.600
C224	CAPACITOR CERAMIC	10nF -20/+80% 50V	*KCK	HE705JYF1032	15.170
C225	CAPACITOR CERAMIC	10nF -20/+80% 50V	*KCK	HE705JYF1032	15.170
C226	CAPACITOR MKT	1000nF 10% 100V	SIEMENS	B32511-D1105-K000	11.233
C227	CAPACITOR ELECTROLYTIC	10uF 20% 35V	* ERO	EKI 00 AA 210 F	14.512
C228	CAPACITOR MKT	100nF 10% 100V	*SIEMENS	B32520-A1104-K	11.219
C229	CAPACITOR MKT	220nF 10% 100V	SIEMENS	B32511-D1224-K000	11.227
C230	CAPACITOR MKT	100nF 10% 100V	*SIEMENS	B32520-A1104-K	11.219
C231	CAPACITOR ELECTROLYTIC	470uF -20/+30% 63V	**PHILIPS	2222 035 68471	14.604
C232	CAPACITOR MKT	220nF 10% 100V	SIEMENS	B32511-D1224-K000	11.227
D201	DIODE ZENER	12V	THOMSON-CSF	BZV47C12	26.750
D202	DIODE	9AV21	PHILIPS	9AV21	25.340
D203	DIODE	MR750	MOTOROLA	MR750	25.219
D204	DIODE	MR750	MOTOROLA	MR750	25.219
D205	DIODE BRIDGE	2KBP04	*GI	2KBP04	27.103
D206	DIODE ZENER	75V BZV47C75	THOMSON-CSF	BZV47C75	26.792
D207	DIODE ZENER	75V BZV47C75	THOMSON-CSF	BZV47C75	26.792
D208	DIODE	1N4002	*MOTOROLA	1N4002	25.100
D209	DIODE	1N4002	*MOTOROLA	1N4002	25.100



POSITION	DESCRIPTION	MANUFACTOR	TYPE	S.P. NUMB	
D210	DIODE F.REC	3A/50V	* MOTOROLA	MR85U	25.225
D211	DIODE ZENER	2.7V BZX83C2V7	THOMSON-CSF	BZX83C2V7	26.606
D212	DIODE	BAV21	PHILIPS	BAV21	26.340
D213	DIODE ZENER	5.1V 5% 0.4W BZX79C5V1	* PHILIPS	BZX79C5V1	26.527
D214	DIODE F.REC	3A/50V	* MOTOROLA	MR85U	25.225
IC201	INTEGRATED CIRCUIT	TDA4718A	SIEMENS	TDA4718A	31.496
IC202	INTEGRATED CIRCUIT	MC1723 CP	MOTOROLA	MC1723CP	31.230
IC203	INTEGRATED CIRCUIT	MC1723 CP	MOTOROLA	MC1723CP	31.230
IC204	INTEGRATED CIRCUIT	LM358N	* NATIONAL	LM358N	31.100
IC205	INTEGRATED CIRCUIT	MC1723 CP	MOTOROLA	MC1723CP	31.230
IC206	VOLTAGE REGULATOR	8V 5% MC78L08ACP	MOTOROLA	MC78L08ACP 5% P.L.HUS	31.158
QC201	OPTO-COUPLER	CNY17-2	*SIEMENS	Q62703-N87	32.530
R201	RESISTOR	470 OHM 5% 2.5W	PHILIPS	2322 192 34701	04.693
R202	RESISTOR	2.2 KOHM 5% 0.33W	PHILIPS	2322 181 53222	01.208
R203	RESISTOR	2.2 KOHM 5% 0.33W	PHILIPS	2322 181 53222	01.208
R204	RESISTOR	18 KOHM 5% 0.33W	PHILIPS	2322 181 53183	01.231
R205	RESISTOR	1.8 KOHM 5% 0.33W	PHILIPS	2322 181 53182	01.206
R206	RESISTOR	1.5 KOHM 5% 0.33W	PHILIPS	2322 181 53152	01.204
R207	RESISTOR	1.5 MOHM 5% 0.33W	PHILIPS	2322 181 53155	01.279
R208	RESISTOR	6.8 KOHM 5% 0.33W	PHILIPS	2322 181 53682	01.220
R209	RESISTOR	1.5 KOHM 5% 1.6W	PHILIPS	2322 191 31502	04.204
R210	RESISTOR	0.22 OHM 10% 4W	PHILIPS	2322 329 34227	05.618
R211	RESISTOR	0.22 OHM 10% 4W	PHILIPS	2322 329 34227	05.618
R212	RESISTOR	1.5 KOHM 5% 1.6W	PHILIPS	2322 191 31502	04.204
R213	RESISTOR	100 OHM 5% 0.33W	PHILIPS	2322 181 53101	01.175
R214	RESISTOR	100 OHM 5% 0.33W	PHILIPS	2322 181 53101	01.175
R215	RESISTOR	8.2 KOHM 5% 0.33W	PHILIPS	2322 181 53822	01.222
R216	RESISTOR	1 KOHM 5% 0.33W	PHILIPS	2322 181 53102	01.200
R217	RESISTOR	1.5 KOHM 5% 0.6W	BEYSCHLAG	MBB0207	03.204
R218	RESISTOR	1.5 KOHM 5% 0.6W	BEYSCHLAG	MBB0207	03.204
R219	RESISTOR	1 KOHM 5% 0.33W	PHILIPS	2322 181 53102	01.200
R220	RESISTOR	1 KOHM 5% 0.33W	PHILIPS	2322 181 53102	01.200
R221	RESISTOR	150 OHM 5% 0.33W	PHILIPS	2322 181 53151	01.179
R222	RESISTOR	1.5 KOHM 5% 0.33W	PHILIPS	2322 181 53152	01.204
R223	RESISTOR	2.7 KOHM 5% 0.33W	PHILIPS	2322 181 53272	01.210
R224	RESISTOR	27 OHM 5% 2.5W	PHILIPS	2322 192 32709	04.660
R225	RESISTOR	100 OHM 5% 2.5W	PHILIPS	2322 192 31001	04.675
R226	RESISTOR	560 OHM 5% 0.33W	PHILIPS	2322 181 53561	01.193
R227	RESISTOR	1 MOHM 5% 0.33W	PHILIPS	2322 181 53105	01.275
R228	RESISTOR	56 OHM 5% 0.33W	PHILIPS	2322 181 53569	01.168
R229	RESISTOR	4.7 KOHM 5% 0.33W	PHILIPS	2322 181 53472	01.216
R230	RESISTOR	2.7 KOHM 5% 0.33W	PHILIPS	2322 181 53272	01.210
R231	RESISTOR	0.11 OHM 10% 5W	PHILIPS	2322 329 35117	05.616
R232	RESISTOR	0.11 OHM 10% 5W	PHILIPS	2322 329 35117	05.616

POSITION	DESCRIPTION	MANUFACTOR	TYPE	S.P. NUMB	
R233	RESISTOR	0.11 OHM 10% 5W	PHILIPS	2322 329 35117	05.616
R234	RESISTOR	1 KOHM 5% 0.33W	PHILIPS	2322 181 53102	01.200
R235	RESISTOR	680 OHM 5% 0.33W	PHILIPS	2322 181 53681	01.195
R236	RESISTOR	8.2 KOHM 5% 0.33W	PHILIPS	2322 181 53822	01.222
R237	RESISTOR	2.7 KOHM 5% 0.33W	PHILIPS	2322 181 53272	01.210
R238	POTENTIOMETER TRIMMING	1 KOHM 20% 0.3W	NOBLE	TM8-KV2-1S	07.784
R239	RESISTOR	560 OHM 5% 0.33W	PHILIPS	2322 181 53561	01.193
R240	RESISTOR	3.3 KOHM 5% 0.33W	PHILIPS	2322 181 53332	01.212
R241	POTENTIOMETER TRIMMING	10 KOHM 20% 0.3W	*NOBLE	TM8-KV2-1S	07.788
R242	RESISTOR	2.7 KOHM 5% 0.33W	PHILIPS	2322 181 53272	01.210
R243	POTENTIOMETER TRIMMING	10 KOHM 20% 0.3W	*NOBLE	TM8-KV2-1S	07.788
R244	RESISTOR	4.7 KOHM 5% 0.33W	PHILIPS	2322 181 53472	01.216
R245	RESISTOR	180 OHM 5% 0.33W	PHILIPS	2322 181 53181	01.181
R246	RESISTOR	56 KOHM 5% 0.33W	PHILIPS	2322 181 53563	01.243
R247	RESISTOR	56 KOHM 5% 0.33W	PHILIPS	2322 181 53563	01.243
R248	RESISTOR	2.2 KOHM 5% 0.33W	PHILIPS	2322 181 53222	01.208
R249	RESISTOR	18 KOHM 5% 0.33W	PHILIPS	2322 181 53183	01.231
R250	RESISTOR	560 OHM 5% 0.33W	PHILIPS	2322 181 53564	01.268
R251	RESISTOR	15 KOHM 5% 0.33W	PHILIPS	2322 181 53153	01.229
R252	RESISTOR	18 KOHM 5% 0.33W	PHILIPS	2322 181 53183	01.231
R253	RESISTOR	2.2 KOHM 5% 0.33W	PHILIPS	2322 181 53222	01.208
R254	RESISTOR	390 OHM 5% 0.33W	PHILIPS	2322 181 53391	01.189
R255	RESISTOR	22 OHM 5% 0.33W	PHILIPS	2322 181 53229	01.158
R256	RESISTOR	1 KOHM 5% 0.33W	PHILIPS	2322 181 53102	01.200
R257	RESISTOR	1.5 KOHM 5% 0.33W	PHILIPS	2322 181 53152	01.204
R258	RESISTOR	2.7 KOHM 5% 0.33W	PHILIPS	2322 181 53272	01.210
R259	POTENTIOMETER TRIMMING	22 KOHM 20% 0.3W	*NOBLE	TM8-KV2-1S	07.792
R260	RESISTOR	56 OHM 5% 0.5W	PHILIPS	2322 182 13569	03.168
R261	RESISTOR	680 OHM 5% 0.33W	PHILIPS	2322 181 53681	01.195
R262	RESISTOR	1 MOHM 5% 0.33W	PHILIPS	2322 181 53105	01.275
R263	RESISTOR	8.2 KOHM 5% 0.33W	PHILIPS	2322 181 53822	01.222
R264	RESISTOR	100 KOHM 5% 0.33W	PHILIPS	2322 181 53104	01.250
R265	RESISTOR	15 KOHM 5% 0.33W	PHILIPS	2322 181 53153	01.229
R266	RESISTOR	51 KOHM 5% 0.33W	PHILIPS	2322 181 53513	01.242
R267	RESISTOR	1 KOHM 5% 0.33W	PHILIPS	2322 181 53102	01.200
R268	RESISTOR	0.11 OHM 10% 5W	PHILIPS	2322 329 35117	05.616
R269	RESISTOR	470 OHM 5% 0.33W	PHILIPS	2322 181 53471	01.191
R270	RESISTOR	3.9 KOHM 5% 0.33W	PHILIPS	2322 181 53392	01.214
R271	POTENTIOMETER TRIMMING	1 KOHM 20% 0.3W	NOBLE	TM8-KV2-1S	07.784
R272	RESISTOR	620 OHM 5% 0.33W	PHILIPS	2322 181 53621	01.194
R273	RESISTOR	68 KOHM 5% 0.33W	PHILIPS	2322 181 53683	01.245
RE201	RELAY	24V DC 10A 2 SK	PASI	KS/U-3-C BU998	21.015
RE202	RELAY	24V DC 10A 2 SK	PASI	KS/U-3-C BU998	21.015
RE203	RELAY	24V DC 10A 2 SK	PASI	KS/U-3-C BU998	21.015

POSITION	DESCRIPTION		MANUFACTOR	TYPE	S.P. NUME
RE204	RELAY	24V DC 10A 2 SK	PASI	KS7U-3-C BV998	21.015
RE205	RELAY	24V DC 10A 2 SK	PASI	KS7U-3-L BV998	21.015
T201	TRANSISTOR	BD650	PHILIPS	BD650	29.088
T202	TRANSISTOR	BD650	PHILIPS	BD650	29.088
T203	TRANSISTOR	BDX34B	MOTOROLA	BDX34B	29.105
T204	TRANSISTOR	BD138	* PHILIPS	BD138	29.057
T205	TRANSISTOR	BC640	PHILIPS	BC640	28.124
T206	TRANSISTOR	BC639	* PHILIPS	BC639	28.120
T207	TRANSISTOR	BC338	PHILIPS	BC338	28.056
T208	TRANSISTOR	BDX34B	MOTOROLA	BDX34B	29.105
TR201	TRAF0	TD3435	TRADANIA	TD3435	22.142
TR202	TRAF0	TD4265	TRADANIA	TD4265	22.150
TR203	TRAF0	TD4265	TRADANIA	TD4265	22.150

POSITION	DESCRIPTION		MANUFACTOR	TYPE	S.P. NUMB
	BLOWER CONVERTER	MODULE 3/300	ESPERA	PRINT NR. S-U-23053A	608336

C301	CAPACITOR MKT	100nF 10% 100V	*SIEMENS	B32520-A1104-K	11.219
C302	CAPACITOR ELECTROLYTIC	47uF 20% 25V	* ERO	EKI 00 BB 247 E	14.524
C303	CAPACITOR MKT	220nF 5% 63V	ERO	MK11818	11.091
C304	CAPACITOR MKT	10nF 10% 400V	SIEMENS	B32510-D6103-K000	11.381
C305	CAPACITOR MKT	10nF 10% 400V	SIEMENS	B32510-D6103-K000	11.381
C306	CAPACITOR MKT	220nF 5% 63V	ERO	MK11818	11.091
C307	CAPACITOR MKT	10nF 10% 400V	SIEMENS	B32510-D6103-K000	11.381
D301	DIODE ZENER	12V	THOMSON-CSF	BZV47C12	26.750
D302	DIODE	1N4148	* ITT	1N4148	25.131
D303	DIODE	1N4148	* ITT	1N4148	25.131
D304	DIODE	1N4148	* ITT	1N4148	25.131
D305	DIODE	1N4148	* ITT	1N4148	25.131
D306	DIODE	BAV21	PHILIPS	BAV21	25.340
IC301	INTEGRATED CIRCUIT	MC1455P1	* MOTOROLA	MC1455P1	31.205
IC302	DUAL TYPE D FLIP-FLOP	MC14013BCP	* MOTOROLA	MC 14013 BCP	33.056
IC303	INTEGRATED CIRCUIT	MC1455P1	* MOTOROLA	MC1455P1	31.205
OC301	OPTO-COUPLER	CNY17-2	*SIEMENS	G62703-N87	32.530
R301	RESISTOR	33 KOHM 5% 0.33W	PHILIPS	2322 181 53333	01.237
R302	RESISTOR	10 KOHM 5% 0.33W	PHILIPS	2322 181 53103	01.225
R303	RESISTOR	33 KOHM 5% 0.33W	PHILIPS	2322 181 53333	01.237
R304	RESISTOR	1.5 KOHM 5% 0.6W	BEYSCHLAG	MBB0207	03.204
R305	POTENTIOMETER TRIMMING	22 KOHM 20% 0.3W	*NOBLE	TM8-KV2-1S	07.792
R306	RESISTOR	33 KOHM 5% 0.33W	PHILIPS	2322 181 53333	01.237
R307	RESISTOR	5.6 KOHM 5% 0.33W	PHILIPS	2322 181 53562	01.218
R308	RESISTOR	100 KOHM 5% 0.33W	PHILIPS	2322 181 53104	01.250
R309	RESISTOR	1.5 KOHM 5% 0.33W	PHILIPS	2322 181 53152	01.204
R310	RESISTOR	10 KOHM 5% 0.33W	PHILIPS	2322 181 53103	01.225
R311	POTENTIOMETER TRIMMING	22 KOHM 20% 0.3W	*NOBLE	TM8-KV2-1S	07.792
R312	RESISTOR	18 KOHM 5% 0.33W	PHILIPS	2322 181 53183	01.231
R313	RESISTOR	1 KOHM 5% 0.33W	PHILIPS	2322 181 53102	01.200
R314	RESISTOR	3.3 KOHM 5% 0.33W	PHILIPS	2322 181 53332	01.212
R315	RESISTOR	8.2 KOHM 5% 0.33W	PHILIPS	2322 181 53822	01.222
R316	RESISTOR	470 KOHM 5% 0.33W	PHILIPS	2322 181 53474	01.266
R317	RESISTOR	8.2 KOHM 5% 0.33W	PHILIPS	2322 181 53822	01.222
R318	RESISTOR	470 KOHM 5% 0.33W	PHILIPS	2322 181 53474	01.266
R319	RESISTOR	1 KOHM 5% 0.33W	PHILIPS	2322 181 53101	01.200
R320	RESISTOR	470 OHM 5% 1.6W	PHILIPS	2322 191 34701	04.191
R321	RESISTOR	1 KOHM 5% 0.33W	PHILIPS	2322 181 53102	01.200
R322	RESISTOR	330 OHM 5% 2.5W	PHILIPS	2322 192 33301	04.687
R323	RESISTOR	1 KOHM 5% 0.33W	PHILIPS	2322 181 53102	01.200
R324	RESISTOR	470 OHM 5% 1.6W	PHILIPS	2322 191 34701	04.191

POSITION	DESCRIPTION		MANUFACTOR	TYPE	S.P. NUMB
R325	RESISTOR	1 KOHM 5% 0.33W	PHILIPS	2322 181 53102	01.200
T301	TRANSISTOR	BC338	PHILIPS	BC338	28.056
T302	TRANSISTOR	BC338	PHILIPS	BC338	28.056
T303	TRANSISTOR	BC548	* PHILIPS	BC548	28.070
T304	TRANSISTOR	MPS A06	* MOTOROLA	MPS-A06	28.410
T305	TRANSISTOR	MPS A06	* MOTOROLA	MPS-A06	28.410

POSITION	DESCRIPTION	MANUFACTOR	TYPE	S.P. NUMB
	INPUT FILTER & FUSES	MODULE 4/400	ESPERA	PRINI NR 5-0-23305A 608345
C401	CAPACITOR MKT	2.2uF 10% 100V	SIEMENS	B32512-E1225-K000 11.406
C402	CAPACITOR MKT	2.2uF 10% 100V	SIEMENS	B32512-E1225-K000 11.406
C403	CAPACITOR MKT	2.2uF 10% 100V	SIEMENS	B32512-E1225-K000 11.406
C404	CAPACITOR MKT	2.2uF 10% 100V	SIEMENS	B32512-E1225-K000 11.406
C405	CAPACITOR MKT	2.2uF 10% 100V	SIEMENS	B32512-E1225-K000 11.406
C406	CAPACITOR MKT	2.2uF 10% 100V	SIEMENS	B32512-E1225-K000 11.406
C407	CAPACITOR MKT	1uF 10% 100V	*ERO	MK11822 11.079
C408	CAPACITOR MKT	1uF 10% 100V	*ERO	MK11822 11.079
C409	CAPACITOR ELECTROLYTIC	2200uF -10/+50% 40V	*ERO	E6 00 MG 422 G 14.720
C410	CAPACITOR ELECTROLYTIC	2200uF -10/+50% 40V	*ERO	E6 00 MG 422 G 14.720
D401	DIODE	MR750	MOTOROLA	MR750 25.219
D402	DIODE	MR750	MOTOROLA	MR750 25.219
F401	FUSE	10A M Ø6.3x32mm	WICKMANN	311030 45.634
F402	FUSE	35A M Ø6.3x32mm	WICKMANN	311035 45.636
L401	COIL	TL354	BB	6-0-23495A 400354

POSITION	DESCRIPTION	MANUFACTOR	TYPE	S.P. NUMB
	24V POWER SUPPLY + T1130	N1407	ESPERA	24V POWER SUPPLY + T1130 808326
C501	CAPACITOR MKC	0.47uF 10% 250V	ERO	MKC1860 12.520
C502	CAPACITOR MKC	0.47uF 10% 250V	ERO	MKC1860 12.520
C503	CAPACITOR ELECTROLYTIC	4700uF 40V	FRAKO	EBA 14.859
C504	CAPACITOR MKC	0.47uF 10% 250V	ERO	MKC1860 12.520
D501	DIODE BRIDGE	50V 6A	*GI	KBPC6005 27.102
D502	DIODE BRIDGE	50V 6A	*GI	KBPC6005 27.102
D503	DIODE ZENER	75V 5W	MOTOROLA	1N5374B 26.970
D504	DIODE ZENER	75V 5W	MOTOROLA	1N5374B 26.970
D505	DIODE BRIDGE	100V 35A	MOTOROLA	BY61 27.130
L501	TRAFO	TD4573	TRADANIA	TD4573 164.159
L502	TRAFO	TD4573	TRADANIA	TD4573 164.159
L503	TRAFO	TD4240	TRADANIA	TD4240 22.149
L504	TRAFO	TD4573	TRADANIA	TD4573 164.159
L505	COIL	TL383		COMPLETE CHOKE TL383 700383
R501	RESISTOR	220 OHM 10% 10W	*ARCOL	HS-10 06.383
R502	RESISTOR	2.7 OHM 5% 2.5W	PHILIPS	2322 192 32708 04.634
R503	RESISTOR	2.7 OHM 5% 2.5W	PHILIPS	2322 192 32708 04.634
R504	RESISTOR	2.7 OHM 5% 2.5W	PHILIPS	2322 192 32708 04.634
R505	RESISTOR	510W S14K50	SIEMENS	Q69-X3135 06.500
T501	TRANSISTOR (PAIR)	MJ802	ESPERA	SORT. TRANS. BUU 49/MJ 802 I SET 700502
T502	TRANSISTOR (PAIR)	MJ802	ESPERA	SORT. TRANS. BUU 49/MJ 802 I SET 700502
T503	TRANSISTOR	BD808	MOTOROLA	BD808 29.095
T504	TRANSISTOR (PAIR)	BUV19	ESPERA	708363 TRANS. BUU19 SET 708363
T505	TRANSISTOR (PAIR)	BUV19	ESPERA	708363 TRANS. BUU19 SET 708363
T506	TRANSISTOR	BD650	PHILIPS	BD650 29.088
T507	TRANSISTOR POWER	BD649	PHILIPS	BD649 29.085
T508	TRANSISTOR	BD650	PHILIPS	BD650 29.088
T509	TRANSISTOR POWER	BD649	PHILIPS	BD649 29.085
TB501	THERMAL BREAKER	SS5 4 B40 4	*COMESA	2509421055040 44.010
TR501	TRANSFORMER	TD0335	TRADANIA	TD0335 22.109
TR502	TRANSFORMER	TD0324	TRADANIA	TD0324 22.108